

B3618

**University of Wisconsin-Extension
Cooperative Extension**

HomeWise

Help for new homeowners



**John Merrill
Kim Terry
Rosalie Powell**

Home Wise



Contents

John Merrill, Kim Terry and Rosalie Powell

Using HomeWise.	1	Money management fact sheets	
Home care fact sheets		Financial planning	
Getting stated		Emergency fund	61
Home care checklist	5	Monthly spending planner —	
Basic tools for home care	9	Where does your money go?.	63
Floors		Escrow accounts.	67
Carpet care	11	If you can't pay your bills.	69
Vinyl floor care	13	Evaluating your insurance needs.	71
Heating and cooling		Home equity	
Energy conservation	15	How much of your home do you own?	75
Furnace care	19	Home equity loans	79
Moisture problems	21	Refinancing your loan?	83
Outdoors		Protect your home equity.	87
Gutter care	23	Taxes	
Ice dams.	25	Income taxes and homeowners	89
Siding care.	27	Property taxes	91
Pest control		Sample property tax bill	93
Carpenter ant control	29	Repair or replace	
Termite control.	31	How long things last.	95
Roach control	33	Should you do a repair yourself?	97
Plumbing		Hiring a contractor for major repairs	
Faucet aerator care	35	and remodeling.	99
Garbage disposal care	37	Hiring someone to help with	
Unplugging sink drains	39	minor repairs	103
Unplugging toilets	41	Homeowner records	
Wiring		Record keeping	
Electrical circuit breakers	43	What to keep, where to keep it	107
Ground fault circuit interrupter	45	Household purchase inventory.	109
Home safety fact sheets		Resources	
Smoke & carbon monoxide detectors	49	Quick reference list	111
Lead paint hazards	51	Homeowner resources	113
Living with neighbors	55		

This publication provides guidelines for home care and management and financial planning. It also introduces regulations that affect Wisconsin homeowners as of 2002. This is not intended to substitute for professional advice, but to help you decide when to seek professional help or to do it yourself.

Reference to products is not intended as an endorsement to the exclusion of others that may be similar. If you use these products, be sure to follow label directions.

Information about homeownership is available from many sources, a few of which are listed in this manual. Information is provided as a convenience to readers. This is not an endorsement by University of Wisconsin-Extension, nor does it cover all issues.

Wisconsin Telecommunications Relay System (WTRS)

- Allows a text telephone (TTY) user who may be deaf, hard of hearing or speech impaired to call anyone using a voice telephone.
- Provides direct-dial TTY access to voice-only phone numbers listed in this booklet, or anyone else you wish to reach with one end of the call in Wisconsin.

Calls may be placed 24 hours a day, 7 days a week. All calls are confidential. To use WTRS, dial 711.

ASCII: (800) 272-1773

Speech to speech: (800) 833-7637

Spanish to Spanish: (800) 833-7813

IN AN EMERGENCY, calling 911 or your local emergency service results in the fastest response time. But if the emergency service does not have a TTY, WTRS communication assistants are trained to help you place emergency calls.

For more information, call:

WTRS Customer Service

(800) 283-9877 (TTY)

(800) 395-9877 (Voice)

Spanish Customer Service

(866) 744-7471

Home Wise

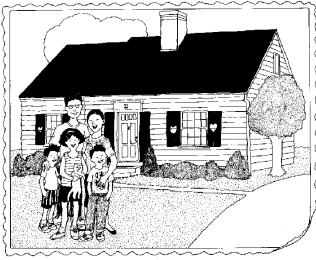

Using HomeWise

Using HomeWise

If you buy a car or a washing machine, you receive an owner's manual that explains how to use and care for it, and what to do if something goes wrong — wouldn't it be great if you got an owner's manual with your new home? *HomeWise* is intended to provide similar use and care information for your new home — especially for first-time homeowners.

For example, how do you take care of the siding? What happens if there is no heat when the weather turns cold? What do you do when your property tax bill arrives? How does being a homeowner save you money on your income taxes?

This manual is in several parts. It begins with a home care section that contains a checklist to use in touring your house to identify care and maintenance tasks. This is followed by brief fact sheets giving suggestions on selecting basic tools to get you started on doing your own repairs and more detail on various care tasks.

Other sections cover home safety, money management and homeowner records and resources.

Your home is a financial asset. How can your financial decisions help protect that investment and see it grow in value? The money management section provides information on a number of such homeowner issues.

The homeowner records section requires some effort on your part. It provides a guide for you to organize records, so you will have what you need when you need it.

This is a place for you to collect such items as use and care manuals for the furnace and other appliances. You may also want to save payment receipts and warranties for major purchases, and complete the quick reference sheet with information and telephone numbers you need as a homeowner.

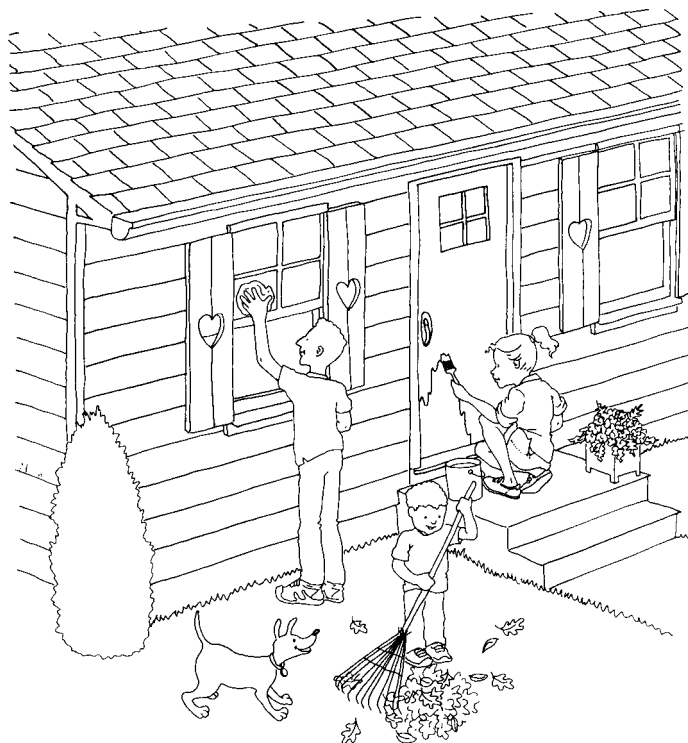

While much of the information in these fact sheets applies regardless of where you live, some applies specifically to Wisconsin homeowners.

This is the second edition of *HomeWise*. Most fact sheets have been revised and others have been added. For example, the new fact sheet “Living with neighbors” recognizes that being a homeowner involves responsibilities and benefits that go beyond your lot line.

This manual comes punched and ready for a three-ring binder. Each fact sheet has the section title in the upper right hand corner so you can quickly flip to the section you want.

We hope this manual will help you enjoy your new home even more.

Partnerships

This edition of *HomeWise* is funded in part by the Metropolitan Milwaukee Fair Housing Council HOME program. HOME program funds also supported training for home ownership counselors and educators offered by the Homeownership Counseling Education Consortium that tested the revision of the *HomeWise* curriculum.

*John Merrill and Kim Terry
University of Wisconsin-Extension
Cooperative Extension
2002*

Home Wise

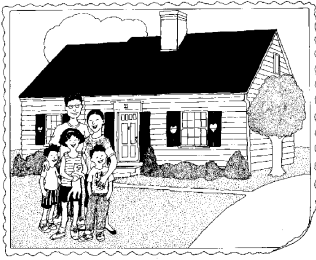

Home care

John Merrill, Kim Terry and Rosalie Powell

I. Home care fact sheets

Getting started

- Home care checklist 5
- Basic tools for home care 9

Floors

- Carpet care 11
- Vinyl floor care 13

Heating & cooling

- Energy conservation. 15
- Furnace care 19
- Moisture problems 21

Outdoors

- Gutter care 23
- Ice dams 25
- Siding care 27

Pest control

- Carpenter ant control. 29
- Termite control 31
- Roach control 33

Plumbing

- Faucet aerator care. 35
- Garbage disposal care 37
- Unplugging sink drains 39
- Unplugging toilets 41

Wiring

- Electrical circuit breakers 43
- Ground fault circuit interrupters . . 45

Add your own home care information to this section.

Home Wise

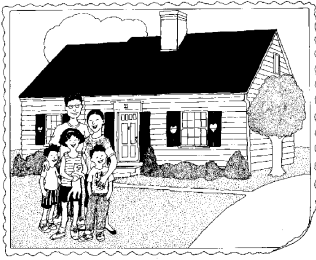

Home care checklist

Getting started

This is a list of things that can help keep your home in tip-top shape. The checklist refers to the series of *Home Care fact sheets* that follows, organized by topic (see contents). Some items in this list refer to use and care manuals that come with equipment in your home, such as the furnace.

The checklist starts in the basement and moves through the house, ending with the exterior and yard.

Check

Furnace

- 1. If the furnace isn't working** — See *Heating and cooling: Furnace care fact sheet*, and your furnace use and care manual.*
- 2.** Check furnace filters every other month, and replace if dirty. See *Furnace care*, and your furnace use and care manual.
- 3.** Most new furnaces have a **condensate line** — a pipe that carries liquid condensed in the furnace to a floor drain. Check to make sure the condensate line is not leaking or clogged. If the pipe clogs, it usually does so behind the access door to the furnace. See furnace use and care manual.
- 4.** Have a technician check the furnace after one year, and at least every other year, depending on the technician's recommendation. This is important for safety, as well as for energy savings. See *Furnace care*, and furnace use and care manual.

Water heater

- 1. If water from hot water faucet is not hot** — See hot water heater use and care manual.* If you do not have the manual, contact a plumber for advice.
- 2. If water is hot enough to scald** — The factory-set temperature may be too high. If so, see hot water heater use and care manual for instructions on reducing the temperature to 120 degrees F.

* **Note:** If you don't have use and care manuals, you may find the instructions you need on the water heater, and on the furnace or inside the access panel. If not, copy down the serial numbers and models. Then, contact local distributors. Ask for the manufacturers' addresses, and write for replacement booklets for the models you own.

Water softener

- 1.** Check softener salt level once every other month, and add salt if less than a quarter full. Salt pellets (as opposed to rock salt) will extend the life of most water softeners.
- 2.** Set the cycle to be sure the softener is providing enough softened water. If white stains develop on sinks and tubs and soap does not lather, the softener needs to cycle more often, or needs more salt. The water softener owner's manual will tell you how to adjust the cycle time. If you feel salt is being used too quickly, lengthen the cycle or consult a technician.
- 3.** The **COLD** water in your home is not softened. Since some sodium is added to water in the softening process, use cold water for drinking, cooking and watering plants.

Clothes dryer

- 1.** Clean dryer lint filter before each use.
- 2.** Check exhaust vent connection for clogging. If the duct is clogged, it can cause a fire in your dryer, or burn out the dryer motor.
- 3.** If the dryer is not vented outside, it may cause moisture to form on your windows and in closets. See *Moisture problems* fact sheet.

Utility shutoffs

- 1.** Check operation of electric service panel. See *Wiring: Electrical circuit breakers*. Make sure circuit breakers are clearly labeled in case you need to shut them off in an emergency.
- 2.** Locate gas shutoffs.
- 3.** Locate water main shutoff.

Tool box

- Be sure you have the right quality tools you need for basic household repairs and maintenance. See *Basic tools for home care*.

Bathrooms

- 1.** Clean tub and shower enclosure with a nonabrasive cleaner at least once a week to prevent mildew and soap scum buildup. Abrasive cleansers can wear away the glossy surface, and make cleaning harder. Look on the label of the product you plan to use. Be sure it states that the product is nonabrasive.
- 2.** Run the bathroom exhaust fan for 15 minutes after showers to remove steam and prevent mildew. If dark stains appear in corners or on the ceiling, this is mold — run the fan longer. See *Moisture problems* fact sheet.
- 3.** Once a year, check the floor under the sink for stains or decay. These are signs that the water or drain lines are leaking.

- 4. If water drains slowly** — Remove the drain plug from the sink, and clean away hair and other dirt. Avoid using harsh chemicals to clean drains. See *Plumbing: Unplugging Sink Drains*.
- 5. If water pressure from the faucet is low** — Clean the aerator. See *Plumbing: Faucet Aerator Care*.
- 6.** Check ground fault outlet several times a year. See *Wiring: Ground Fault Circuit Interrupter*.

Kitchen

- 1.** Check under the sink to be sure disposal, drains and water connections are not leaking. Spots on cabinet floor indicate leaks.
- 2.** Clean refrigerator condenser coils with a brush or vacuum twice a year. Check refrigerator owner's manual for location of coils. They may be behind or on the bottom of the refrigerator.
- 3.** On no-frost refrigerator, locate defrost pan. This pan collects water during defrost cycle. It should be emptied and cleaned regularly.
- 4.** Use baking soda to remove stains from kitchen counters. **DO NOT** use scouring powder, as it will scratch the surface and make it harder to clean.
- 5.** Sweep vinyl flooring daily, and follow manufacturer's directions or clean with clear, cold water once a week. If detergent is used, rinse thoroughly. Unless detergent is thoroughly rinsed away, it will dull the surface. Most modern floors do not require waxing. For information on removing stains, see *Vinyl floor care fact sheet*.
- 6.** Clean the range hood filter with hot water and dishwashing liquid monthly, more often if you frequently fry or broil foods.
- 7.** Only use water from the cold water faucet for drinking. Cold water is less likely to contain harmful dissolved metals such as lead. For extra protection, run the water for 30 seconds or until it runs cold before using.
- 8. If garbage disposal does not work** — See *Garbage disposal care fact sheet*.
- 9.** Use cold water with disposal. Leave water running after the disposal sounds clear, to be sure garbage moves down the drain.
- 10. DO NOT** put bones, metal or stringy material down the garbage disposal.

Heating registers

- Remove main return register yearly, and vacuum out dirt. This is a large register, usually located in the living room or hall.

Smoke and carbon monoxide detectors

- Check once a month to make sure smoke detectors on each level of the house are operating. See their use and care manuals and *Smoke and carbon monoxide detectors fact sheet*.

Carpeting

- 1. Vacuum heavy use areas often.
- 2. Place scatter rugs or remnants at entry areas and other high traffic areas — such as walkways or under the dining table — to protect carpet. Put mats in front of sinks.
- 3. Blot stains when they occur. **DO NOT** rub them; this can spread a stain, and force it deeper into carpet. For information on removing stains, see *Floors: Carpet care*.

Windows

- 1. **If the insides of windows collect water in winter** — Wipe windows off so moisture doesn't cause wood to rot. Water on windows may be a sign that you have too much humidity in the house. See *Moisture problems* fact sheet.
- 2. **If your home has interior screens** — Remove screens from windows in winter to reduce the amount of water that collects.

Exterior

- 1. Clean gutters and downspouts in the fall after leaves have fallen, and any time water continues to drip from downspouts several days after a rain. See *Gutter care* fact sheet.
- 2. Be sure downspouts direct water well away from the foundation, to reduce chances of a wet basement and to prevent erosion near the house. See *Gutter care* fact sheet.
- 3. Be sure ground next to the house slopes down to carry water away from the house. Low places next to the house lead to basement water problems.
- 4. Trim shrubbery or trees that touch your house, to prevent damage to your roof, siding or windows.
- 5. If you have central air conditioning, keep grass, weeds and shrubbery away from the condenser. For it to operate efficiently, air must move freely around the unit.
- 6. Wash siding with water and a soft brush annually. See *Outdoors: Siding care*.
- 7. In the fall, disconnect hoses from outside faucets **BEFORE** the temperature drops below freezing. Water trapped between the hose and faucet may freeze and cause the faucet to burst.
- 8. Coat an asphalt driveway with a sealer annually, to prevent water penetration and help the driveway last longer.
- 9. In winter, avoid using salt on concrete sidewalks and stairs. Salt can damage concrete. Salt water running off driveways and sidewalks can damage trees and lawns, and cause problems in local rivers and lakes. Look for deicers that indicate they do not harm concrete.

Home Wise

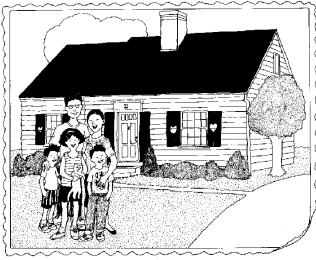

Basic tools for home care

Getting started

Use the right tool.

It is important to have the right tool for the job. Using the wrong size screwdriver can damage the head of the screw. Using a screwdriver in place of a chisel or pry bar can damage the screwdriver.

The tools listed below are ones the authors find useful for the basic home care and repair tasks in this manual.

As you begin to do more complicated tasks, you will find that you need to add other tools — that chisel or pry bar, or a certain type of saw. The sales staff at your local hardware store or lumber yard can help you select tools you need to buy or rent for a particular task.

Quality can be important in choosing a tool.

It is also important to get good enough quality tools to do the work. For example, some screw drivers are made of metal that chips easily or that bends when you apply pressure to turn a screw. Better quality screw drivers will not do this. In fact, some are guaranteed so you can return them to the store that sold them for a replacement. Keep the receipts for your records (see *Record keeping: What to keep, where to keep it*).

Locking pliers

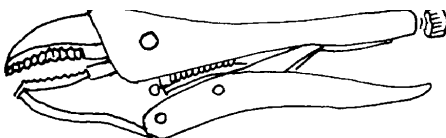

Some basic tools

Hammer, claw — 16 ounce

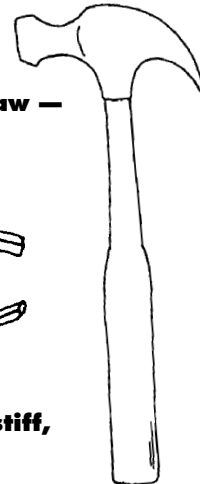

Pliers

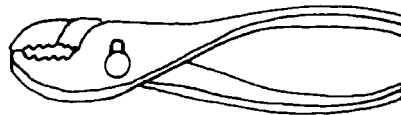

Putty knife, flat-bladed and stiff, 1 or 2 inches wide

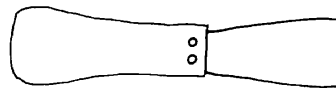

Level — 2 foot

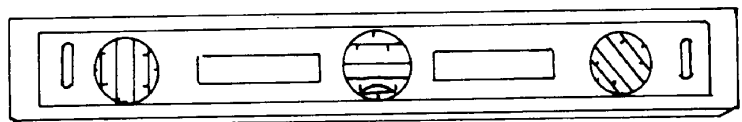

Wrench, adjustable — 10 inch size

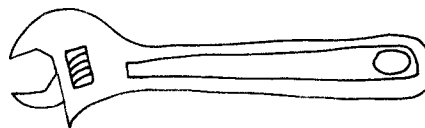

Screwdriver, Philips head — number 2

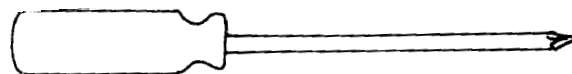

Screwdriver, flat bladed — number 2

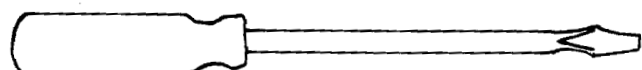

Home Wise

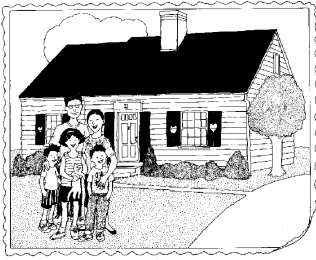

Carpet care

Keeping carpeting clean

Use door mats or scatter rugs at entrances and in front of sinks to trap dirt before it reaches the carpet. Clean mats frequently by vacuuming, sweeping or shaking outside to be sure dirt isn't tracked from them onto the carpeting.

Sweeping the surface is not enough. Vacuum carpets regularly. Concentrate on heavy traffic areas, and other areas that collect dirt such as under the dining table. You can't vacuum too often. A vacuum with a rotating beater bar and strong suction is essential to removing dirt from the carpet base. Keep the brushes clean, replace brushes when they wear out, and change the bag according to instructions.

Before you use a cleaning product on new carpeting, check the manufacturer's guide for restrictions. Most new carpeting has a stain-resistant surface; ask the carpet dealer what type of cleaner to use. Follow the instructions on the cleaner container.

Removing stains...

Food

- Clean up a spill quickly before it gets into the carpet.

For **liquids**, blot with a clean cloth or sponge. Blot toward the center of the spill so the spot won't spread.

DO NOT rub.

For **gooey spills** like jam or gum, scrape up as much as possible with a pancake turner or dull knife. Use ice in a plastic bag to stiffen and remove gum.

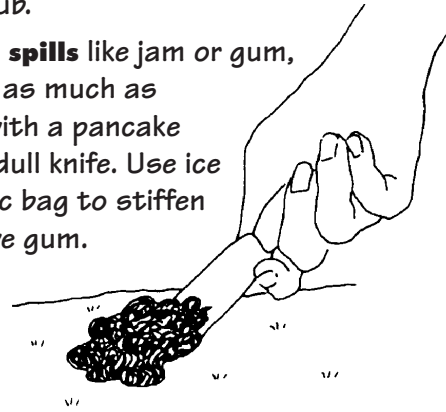

- Spray or sponge on a cleaning solution made of:
 - 1 teaspoon non-bleaching laundry detergent
 - 1 teaspoon white vinegar
 - 1 quart warm water

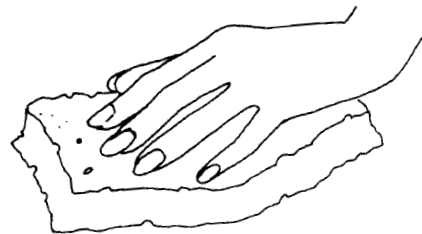

- Blot stained area with clean, light-colored cloth or paper towels. Change towels frequently to avoid restaining. Add more cleaning solution, and repeat until towels stop picking up stain. **DO NOT** rub detergent into the carpet.

Oil, grease or ink

- Immediately blot or scrape up as much as possible.
- Spray or sponge on a dry cleaning solvent. Carpet spot removers are available in hardware and grocery stores. Follow label directions. Many contain solvents that may be dangerous to breathe. Use these only when you can open windows and run fans.
- Blot stained area with clean, light-colored cloth or paper towels. Turn or change towels frequently to avoid restaining. Add more cleaner, and repeat until towels stop picking up stain. **DO NOT** rub cleaner into carpet.

Carpet cleaning

There are several methods of carpet cleaning:

- **Dry crystals.** Brush crystals into the carpet. The dry cleaning solution dissolves, and absorbs oils and greasy dirt. Let dry and vacuum. This method is effective for carpets that are not too dirty. You can also use talcum powder or cornstarch.
- **Spray foams.** Work foam into carpet with a sponge or brush, let dry and vacuum. This method can be effective for small areas, but cleans only the carpet surface.
- **Liquid shampoos.** Select a shampoo that foams well and dries to a powder. Dilute if concentrated. Work shampoo into carpet with a rotary brush, let dry and vacuum. This method is good for cleaning moderately to heavily soiled carpet. It restores color and fluffs up carpet pile, but brushing can mat deep pile.
- n Hot water ("steam") extraction. You can hire professionals — or do this yourself. Easy directions come with rental equipment. A hot water and detergent mix is forced into the rug to flush out dirt, and immediately vacuumed up. This method is effective at removing dirt deep in the carpet. **Note:** Mold will develop unless all the water is carefully removed. Opening windows and running exhaust fans will speed drying.

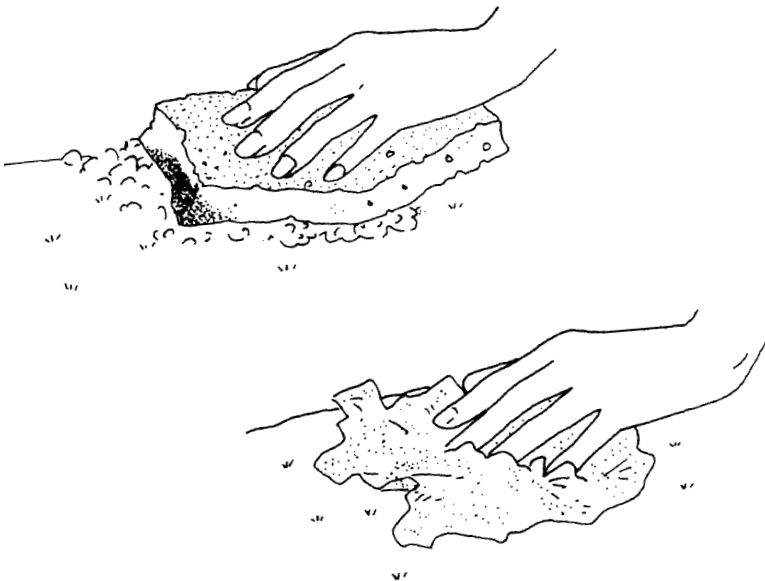

Adapted with permission from *Caring for Your Carpet* North Central Regional Extension Publication 462, by Sharon Stevens and Wanda Eubank (Columbia, Mo.: Cooperative Extension Service, University of Missouri and Lincoln University), 1993.

Home Wise

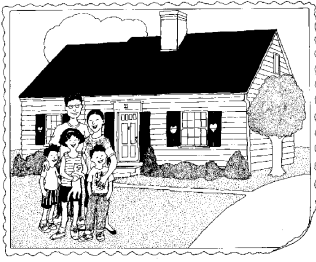

Vinyl flooring care

Keeping the floor clean

Here are some ways to keep vinyl floors looking good:

- **Protect the floor when you move.** Moving appliances or heavy furniture across the floor can scratch or gouge it. Try upside down carpet scraps under furniture legs, or “walk” an appliance on pieces of plywood or paneling.
- **Use door mats and small rugs by entry doors.** Sand and other outside dirt can scratch the floor surface, and make it hard to clean. Avoid mats with rubber backing, since they can damage floors.
- **Sweep or vacuum daily** to remove loose dirt that can scratch the floor.



- **Wipe up spills immediately.** If you leave spills until later, they can cause stains or attract more dirt.
- **Use floor protectors** to prevent furniture legs from denting or gouging floors. These are available at flooring and hardware stores.
- **Damp mop floor with:**
 - Cleaning solution recommended by flooring maker, or
 - All-purpose cleaner such as liquid Spic and Span.[®]
- Apply cleaner to a small area 3 feet by 3 feet.

Let the cleaner set on the floor for a couple of minutes, then rinse thoroughly with clean warm water. If you do not rinse thoroughly, the remaining cleaner will cause the floor to soil more quickly. A scrub brush may help to loosen dirt on a rough-surfaced floor.

* Reference to products is not intended as an endorsement to the exclusion of others that may be similar. If you use them, be sure to follow the manufacturer’s current label directions.

Restoring the shine

Most vinyl floors have “no wax” surfaces. This means that you do not have to wax them often. But you may need to renew the shine. Use a floor polish made for vinyl floors. The company that made your flooring may recommend special types of polish. Some types of vinyl floor polishes are available in grocery stores. Be sure to apply thin coats of polish. To get an even coat, pour polish on the applicator rather than the floor.

Removing stains...

Food

- Wipe up excess with a clean, white cloth, or lift with a pancake turner.
- Wash the area with detergent floor cleaner. Let soak a few minutes. Rinse well.
- If the stain is not gone, use more detergent, and rub with a nylon scrub pad or brush.
- If stain is still not gone, wipe with rubbing alcohol (isopropyl or denatured).

Tar, asphalt, chewing gum

- Apply ice to harden, then chip off with a dull knife or putty knife.
- Use paint thinner or lighter fluid to rub away remainder. Use in a well-ventilated space, and follow label directions.

Heel marks

- Wash with detergent floor cleaner using a nylon scrub pad or brush. Soak a few minutes if necessary. Rinse well.
- Pour a small amount of baking soda in a bowl. Dampen a clean, white cloth, and dip the cloth into the soda to get enough powder on the cloth to form a paste. Rub the scuffed area in a circular motion. Rinse thoroughly with water. Buff with a towel if the area appears dull. Some manufacturers suggest cleaning heel marks with lighter fluid and a clean white cloth. Lighter fluid is flammable, so use with care.

After removing a stain, you may want to apply floor polish to the area to renew the shine and protect the floor. See *Restoring the shine* above.

Adapted with permission from instruction booklets produced by Armstrong, Congoleum, Mannington Resilient Floors and Tarkett.

Home Wise

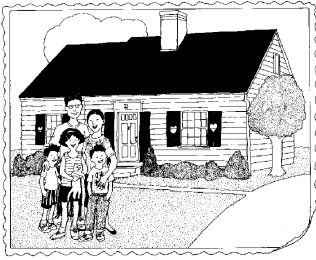

Energy conservation

Heating & cooling

Keeping heating costs down

Your winter heating bill can be an unpleasant surprise — and a real strain on the household budget. In northern climates, natural gas or fuel oil bills are often \$100, \$200 or more a month during winter.

One way to manage this seasonal expense is to ask your utility company to place you on a budget plan. This means that you will be billed an equal amount each month based on the previous owner's average energy use. Payments are adjusted annually to reflect most recent actual usage.

To reduce heating costs:

- Reduce air leakage.

Make sure the weatherstripping around windows and doors is in place and still springy so it makes a tight seal. If warm air leaks out, you'll see frost on the storm window.

New exterior doors have adjustable sills. Make sure you do not see any light showing under the door. If you do, loosen or tighten the adjustment screws in the sill. These will raise or lower the sill as needed.

Check caulking around window and door frames, at butt joints in siding, and where wood siding meets corner trim. Caulking is used to fill gaps and prevent air and moisture leaks. If you find loose caulk, remove the old caulk, clean the area and apply new caulking.

- Lower your thermostat to save energy.

Perhaps the easiest way to save heating dollars is to dial down. If you will be away for several hours or more, turn the thermostat down to 55 or 60 degrees F. Also consider dialing down at night and keeping the temperature lower even when you are home.

Having the temperature at 65 degrees rather than 70 degrees may take some getting used to. But many people find a cooler house more comfortable and healthy once they are used to it. You will save about 1 percent on your heating bill for every degree you dial down.

Installing a **programmable or set-back thermostat** will make it easier to dial down and have the house warmed up when you wake in the morning or come home at night.

Ask your gas or oil supplier for details on weatherizing your home and setting up budget payments.

For help selecting energy-savers such as programmable thermostats, visit the U.S. Environmental Protection Agency (EPA) Web site:

www.energystar.gov/products

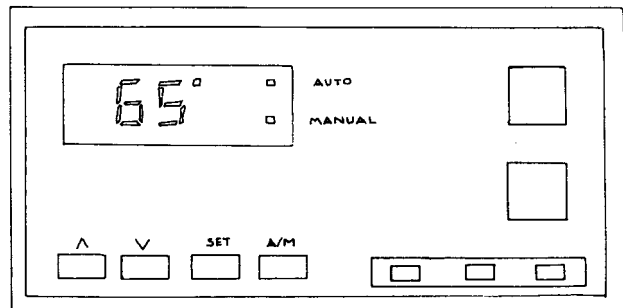

Keeping cool in summer

You can save money on your summer electric bill by following a few simple steps when you use air conditioning.

Ways to keep central air conditioning costs down:

- **Close storm windows and lower drapes and blinds** to keep out as much heat as possible.
 - **Check furnace filters** to be sure they are clean and air flows freely.
 - **Keep the thermostat set as high as you can tolerate**, and move it up a few degrees when you are away for more than a couple of hours. The air conditioner will still reduce humidity and make the house comfortable even at warmer temperatures.
 - **Use fans** to circulate air when you feel warm.
 - **Run exhaust fans** after bathing to remove as much moisture as possible. Be sure your clothes dryer is vented outside, and line dry clothes outdoors if possible.
 - **Turn off your dehumidifier.** The air conditioning may drop the basement temperature to the point where the condenser coils on a typical dehumidifier will freeze. The air conditioning will also drop humidity levels enough that the dehumidifier is not needed, and running it would just waste energy.
- **Close off registers** in rooms you don't use.
 - **Close doors** to keep cooler air in the area you use.
 - **Ventilate the attic.** Attics in older homes should have one square foot of ventilation opening for every 150 square feet of floor, divided equally between the ridge area and bottom edge of the roof. Air flows in through vents in the eaves, pushing hot air up and out vents near the ridge.
 - **Plant shade trees** to keep the sun from striking your home. In the long term, planting shade trees on the south and west sides can keep your home cooler. Plant trees well away from the house.



Keeping costs down with room air conditioners

- Make sure the unit is the right size to cool the room.
 - If the unit provides cool air up close but leaves the rest of the area warm, it may be too small. Shut doors to reduce the area to be cooled.
 - If the unit shuts off frequently and the room feels cold and clammy, it may be too large. The unit is cooling without dehumidifying adequately, meaning you should cool a larger area or buy a smaller air conditioner.
- **Turn off** room air conditioners when you leave for long periods of time.
- **Use higher fan speed to increase comfort.** Adjust the directional fins to avoid uncomfortable breezes.
- **Clean the filter and evaporator.** When these are dirty, you have less air flow and cooling. See the unit's use and care manual for cleaning instructions.
- **Check the seal around the unit.** Make sure warm air isn't leaking in around the air conditioner.
- **If you use an extension cord, be sure it is rated for high current flow.** Using the wrong extension cord can be a fire hazard and reduce the unit's cooling ability.

Insulating helps in summer as well as winter

Your house will remain cooler in summer as well as warmer in winter if the attic and side walls are well-insulated.

An insulating value of R-38 or more is recommended for the attic — at least 12 inches of insulation on the attic floor — and R-19 for the walls. Consult your utility company or home inspector.

Home Wise

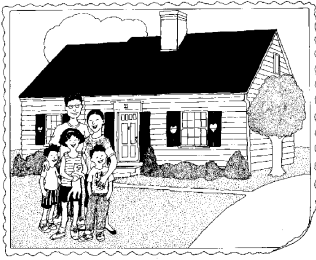

Furnace care

This fact sheet covers basic information on caring for forced air furnaces. The information is general, so read your owner's manual, or consult a furnace repair technician for specific instructions for your furnace.

What to do...

If you smell gas:

- Leave the house immediately, and call the gas company from a neighbor's home.
- Follow the gas company's instructions.

If the furnace won't start:

- Check to be sure the electrical switch on the furnace is on, and that the circuit breaker for the furnace is on.
- Check to be sure the thermostat is set higher than the room temperature on the thermometer.
- If your furnace vents exhaust through plastic pipes, make sure the outlets for the pipes are not blocked. The furnace will automatically shut off if these pipes are blocked.
- If your furnace vents exhaust through plastic pipes, it also may have a plastic tube leading to a basement floor drain. If this tube — known as a **condensate line** — is plugged, the furnace will automatically shut off.
- If the furnace still won't start, call your furnace service company or the gas company.

Have your furnace checked regularly.

There are four good reasons to have a heating contractor check your furnace at least once every other year.

- 1. Safety** — Gas furnaces are generally safe, but they can create carbon monoxide — a deadly odorless gas.
- 2. Energy efficiency** — Like a well-tuned car, a well-tuned furnace uses less energy.
- 3. Convenience** — A checkup can keep you from waking up in the middle of the night to find the house cold and the furnace not operating.
- 4. Emergency repairs** — A company that has serviced your furnace is more likely to be willing to respond quickly in an emergency.

Change filters when dirty.

Your furnace has one or two filters that clean the air that circulates through your home. When the filter gets dirty, less air can get through the filter, so your furnace has to work harder.

Before the heating season, check your filter size and get extras to have on hand. You can get replacement filters at stores that sell household supplies and hardware.

During the heating season, check the filter every other month, and change it if it is dirty.

To change the filter:

- Turn off electricity to furnace.
- Remove the access door.
- Remove the **filter retainer** — metal clip that keeps filter in place.
- Pull out the filter carefully, keeping the dirty side up.
- Replace a fiberglass filter with a new one the same size, from a drug store or hardware store.
- If you have a reusable filter and the filter isn't ripped, take it to a sink or outside. Run water through it, holding the dirty side down while cleaning. Shake out extra water when done.

- It is important that the filter face the right direction when installed. Some filters have arrows on the edges indicating how they should be installed. When in doubt, be sure that the mesh covering the filter faces toward the blower to keep the filter material from being sucked into the blower.
- Replace the access door, and turn on the electricity.

Should you upgrade your furnace filter?

The basic furnace filter is designed to remove large particles that reduce furnace efficiency. In response to consumer concern for indoor air quality, more efficient filters are now being marketed.

Here are some things to think about before you upgrade your furnace filter.

- First, filters only clean air when the furnace blower is operating during the heating season, and then only about 20 percent of the time.
- Second, recent research suggests that filters have relatively little impact on overall dust levels, which are much more affected by household activity.
- Third, dust that appears on surfaces is so heavy that it typically doesn't stay in the air long enough to be removed by any of the filter options.

Nevertheless, if you have family members with allergies who require cleaner air, then you may want to invest in a high efficiency furnace filter. If you do, check the operating, installation and replacement costs — not just the initial purchase price.

The electronic filter that has been around for many years is among the most effective. It has a high initial cost but no operating costs, provided you keep it clean.

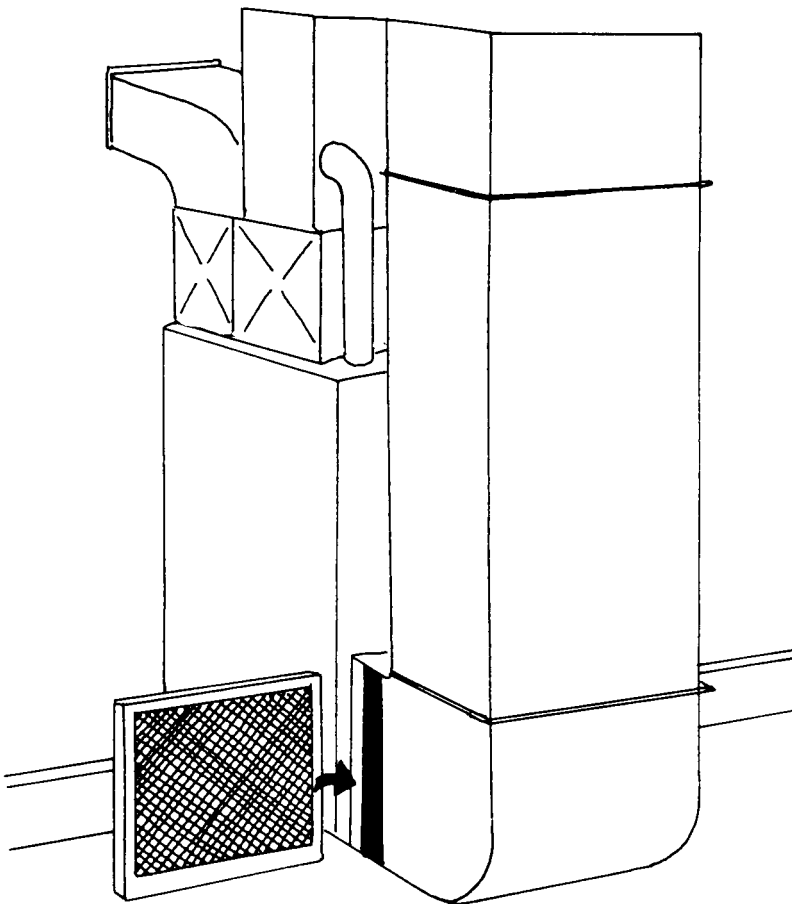

Furnace filter upgrade adapted with permission from: *About Your House: Your Furnace Filter* © 1999 by Canada Mortgage and Housing Corp.: www.cmhc-schl.gc.ca

Home Wise

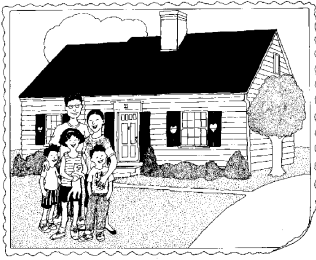

Moisture problems

Heating & cooling

Water on the windows — Mold on the walls

Some houses are so airtight that humidity is trapped inside during the winter. When this happens, windows may become fogged and stay that way. You may also see dark spots on the walls in your bathroom or on the outside walls of bedrooms. This is mold. Windows fog and mold forms because water from humid air is condensing on cold surfaces.

Ways to deal with humidity problems:

- **Check for plumbing leaks.** Check under sinks, tubs, toilets, around the water softener, furnace and washer for drips, wet places or stains.
- **Vent dryer outdoors.** Be sure the clothes dryer is venting outside.
A clothes dryer venting indoors releases a gallon or more of water into the house for every load you dry.
- **Keep basement dry.** Make sure that water is draining away from the outside of your home. If not, water could be coming through basement walls and adding to your humidity problem. See *Gutter care* fact sheet.

Moisture sources in the home

Shower — 1/2 pint per shower

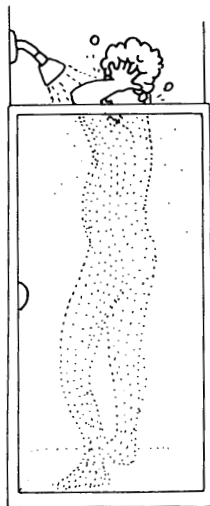

**House plants
up to 1 pint per day**



**Breathing —
3 pints per day**



**Cooking and dishwashing
1 pint per meal**



- **Increase ventilation.** Use your range hood when cooking, cleaning or doing dishes. Use bath fans for 15 minutes after showering or bathing. Fans will only help humidity problems if they are vented outside. If humidity is still a problem, leave fans on for several hours per day. Open a window about 1 inch at the other end of the home to provide replacement air when the fan is running.
- **DO NOT use a dehumidifier in winter.** Most dehumidifiers are meant to work at temperatures of 65 degrees F or warmer, and with humidity levels above 50 percent. During winter, increasing ventilation is more effective, and costs less.

Summer basement humidity problems

If your basement smells musty during summer and no water is leaking in, humidity may be the problem. Warm air from upstairs falls into the basement and cools off. Cooler air can hold less moisture, so some water condenses.

Opening a window usually doesn't add enough heat to stop the problem. In fact, doing so may just bring in more moisture. A dehumidifier is usually the best solution in the summer.

Dealing with mold problems

Reducing relative humidity and eliminating leaks and damp surfaces are the best long-term treatments of mold problems. But if you find small areas of mold on surfaces, you can use the following procedure to eliminate it.

Scrub the area with a solution of $\frac{1}{3}$ cup full strength household detergent; 1 cup of 5 percent household bleach solution (sodium hypochlorite) and 9 cups of water.

Rinse carefully to remove the remaining cleaning solution and mold residue. Even dead mold spores can cause allergic reactions. See health precautions below.

Caution: Be sure the detergent does not contain ammonia. Bleach is a strong chemical. Follow the directions on the container carefully. Wear rubber gloves and avoid skin contact. Open windows and run fans to ensure adequate ventilation.

For larger areas, for confined spaces such as crawl spaces, and for areas where mold has penetrated materials, surface cleaning is not enough and more health precautions are needed.

- Remove and replace porous materials such as wall board or ceiling tiles.
- Clean mold from wood and masonry and sand off any remaining stains.

Once surfaces are thoroughly free of mold, apply paints and sealers containing fungicides to inhibit future mold growth.

Health precautions

Molds can cause serious health problems including allergic reactions, asthma attacks and other problems. Therefore, it is vital to use extreme caution when working with large concentrations of mold. Wear a N95 disposable respirator, rubber gloves and eye protection.

Isolate the work area from the rest of the house and use a HEPA (high efficiency particulate air filter) vacuum to clean the space once the area is cleaned.

You are safest to hire a professional restoration contractor who specializes in mold remediation to do the clean up. Contact your local health department for help in locating mold removal contractors.

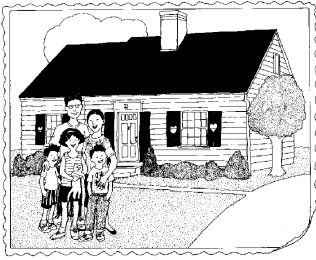

Gutter care

Gutters keep water that flows off your roof out of your basement and foundation. Check gutters in the fall and spring to make sure they are doing their job.

Clean gutters regularly.

Clean out leaves, mud and twigs with your hands, a trowel or an old pancake turner. Have a helper hold the ladder so it doesn't slip.

Water trapped in the gutter means a plugged downspout. To unplug the downspout, use a garden hose. Place the end of the hose in the top of the downspout. Then, have a partner on the ground turn on the water. Snake the hose down the spout until clear water is running out the bottom.

From the ground, check to be sure the downspout directs water away from the house. If there is a hole in the ground where the downspout ends, add an extension to carry water farther from the house. Add a splash block, bricks or flat rocks under the spout to spread the water.

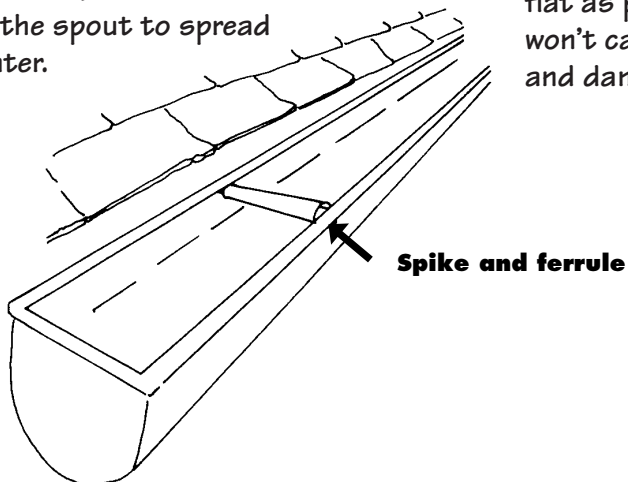

Check supports.

When cleaning gutters, check to make sure they are fastened tightly to the house and aren't sagging. If gutters pull away from the house, water will fall to the ground behind them. If gutters sag, water will collect in the low points and cause them to sag further.

Repair holes.

You can repair small holes in the gutter with an old piece of window screening and some roofing cement. Clean the area carefully to get rid of all loose dirt and rust. Apply a layer of roofing cement, and press the screening into it. Make the patch as flat as possible so it won't catch debris and dam water.

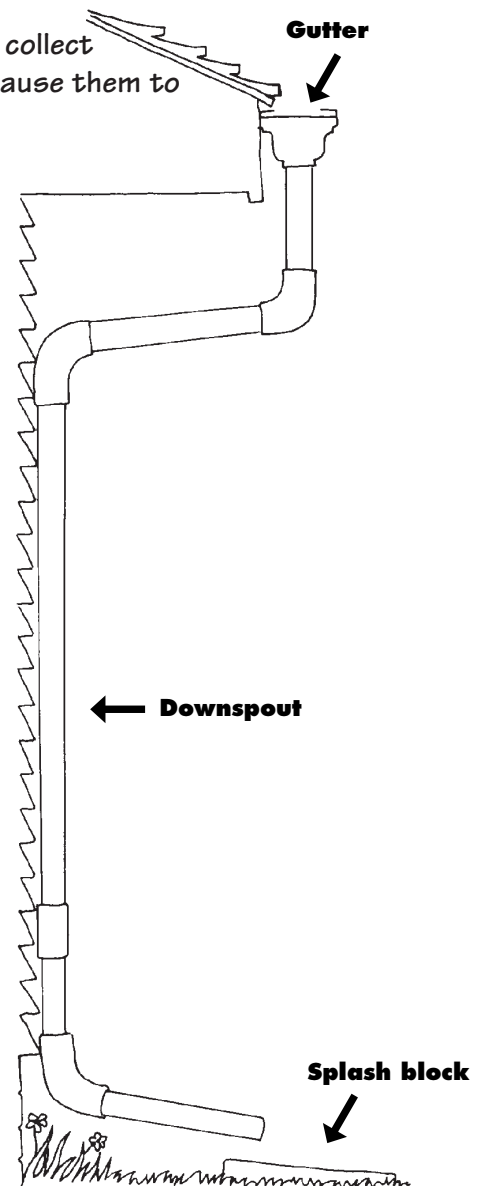

Home Wise

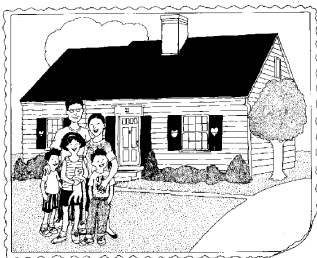

Ice dams

Icicles can mean problems

While icicles hanging from the eaves of your home may be beautiful, they may also indicate ice dams. Ice dams form when snow piles high on the roof and the weather stays cold.

Under these conditions, snow touching the roof often melts. Water runs down the roof under the snow to the eaves. There, the roof temperature drops and the water refreezes. As this ice dam melts, water drips over the eaves and creates icicles.

As more snow melts, water flowing along the roof may back up behind the dam and leak into the attic or sidewalls of the home, causing damage.

First aid for ice dams

Clear snow from the roof a few feet back from the eaves with a roof rake. You need only remove snow far enough back so the meltwater does not reach the ice dam.

A **roof rake** has a rectangular piece of aluminum where the teeth would be on a garden rake, and a handle that extends to 15 feet. This rake is designed so you can remove the snow from the ground.

You do not need to remove snow completely. **A thin layer of snow:**

- **Protects shingles from the roof rake.**
- **Keeps the roof cold enough** so no more water flows down the roof to add to the ice dam — or
- **Simply melts away.**

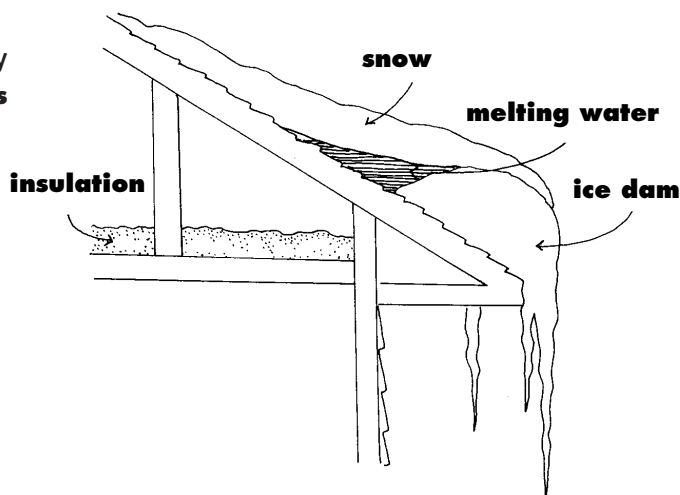

Do not try to break up ice dams. Using picks and axes to break up ice could damage shingles. Usually, removing the snow behind the dam as described above will stop both water damage and ice buildup behind the dam.

If icicles hanging from the dam become large, it's OK to remove them to reduce the weight on the gutters.

If you cannot reach the eaves from the ground with a long-handled roof rake, consider hiring a roofing contractor. They have the equipment to work on the roof safely.

How can you prevent ice dams?

To prevent ice dams, make sure your attic stays cold.

Check for air leaking into the attic.

Look around chimneys and plumbing. Non-expanding foam in a can will plug most leaks. If air leaks around something hot like a stove pipe, form a gasket with sheet metal or use fiberglass insulation that will not burn or melt.

Add insulation. In northern climates, the attic should have an **insulating value of R-38 or more — at least 1 foot of insulation on the attic floor.** Consult your utility company or home inspector for recommendations in your area.

Ventilate the attic. In older homes, attics should have 1 square foot vent opening for every 150 square feet of floor, divided equally between the ridge area and bottom edge of the roof (*eaves*). Cold air flows in through vents in the *eaves*, pushing warm air up and out vents near the ridge.

Home Wise

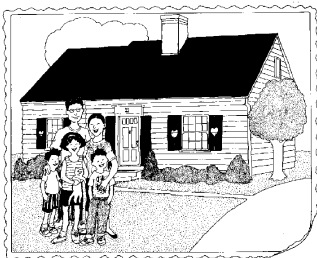

Siding care

Here are some suggestions that will help care for the siding on your new home. Unless indicated, suggestions apply to aluminum, steel, vinyl, and wood siding.

Keep siding clean.

- **Wash siding every year with cold water.** Use a soft brush to loosen dirt. A long-handled car washing brush that fastens on the end of a garden hose makes the job easier.
- **Start from the bottom and work up,** to prevent streaking.
- **For hard to remove dirt,** wipe down the siding with:
 - 1/3 cup household cleaner such as Soilex® or Spic and Span® in 1 gallon of water.
 - For vinyl siding: If this does not work, increase the household cleaner to 2/3 cup and add 1/3 cup laundry detergent.
- **Rinse siding well with clear water.**

Remove mildew.

Dark spots near the ground or under overhangs in shaded areas may be mildew. To remove mildew:

- **Add 1 quart of household bleach** to the cleaning solution above for vinyl siding (see the caution below).
- **Protect shrubs** from contact with the bleach solution by covering them with clear plastic.
- **Scrub spots with the bleach solution, then rinse siding well with clear water.**

Caution: Be sure the household cleaner you use in this mixture **does not contain ammonia.** Ammonia can form a poisonous gas when mixed with the chlorine in bleach.



Remove chalking from painted siding.

Natural weathering can make paint powder — chalk — on wood, aluminum or steel siding. You can generally wash chalking off with water and gentle scrubbing.

Use power washers with great care.

Do not tilt it up, as this can force water behind the siding. It will drip down later, streaking your clean siding. Water behind siding can also cause damage to your home. Using too much pressure can remove paint or damage the siding.

Repair loose vinyl siding. Loose vinyl siding can either be snapped back into place or loosened and renailed. Talk to a vinyl siding supplier for details and the tools needed.

Adapted with permission from:

Knaebe, Mark, "Why House Paint Fails," *The Finish Line*. Forest Products Laboratory, USDA Forest Service, 1995: www.fpl.fs.fed.us/faqs.htm

Vinyl Siding Cleaning and Maintenance Guide © 2000 Vinyl Siding Institute:
www.vinylsiding.org/vsic/publications/clean.htm

Prepared by John Merrill, extension housing specialist, UW-Madison.

R-02

Home Wise

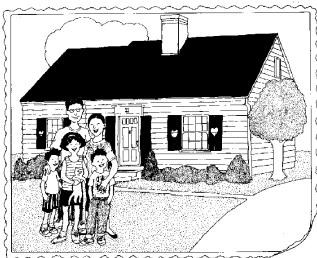

Carpenter ant control

What are carpenter ants?

If you see large black ants in your home, they are probably carpenter ants.

Carpenter ants **do not** eat wood, but feed on live or dead insects. Indoors, they are attracted to meat, honey, sugar, jelly, grease and fats. If nesting indoors, they may be found in water-damaged or decaying wood, foam insulation, or cavities such as hollow core doors, behind walls, or even in curtain rods.

Outdoors, carpenter ants nest in dead or rotting trees and stumps, in landscape timbers, or in logs and boards lying on or buried in the ground.

How to identify carpenter ants

Carpenter ants are usually black and range from $\frac{3}{8}$ to $\frac{1}{2}$ inch long. Some carpenter ants have wings, though most members of the nest do not.

Carpenter ants have a rounded thorax, while other ants have an uneven thorax. You can tell winged carpenter ants from termites, because ants have waists and termites don't (see illustration).

When are carpenter ants a problem?

It is common to see a few carpenter ants in the home during the spring. However, you may have a nest in your home if you see any of the following:

- **Carpenter ants inside from November to early March.**
- **Many winged carpenter ants inside.** The swarm may help you locate the nest.
- **Coarse sawdust mixed with insect parts (called frass) falling from ceilings, cabinets or other wood.**
- **Many workers** — 15 to 20 per day — in places other than the kitchen.

Carpenter ant

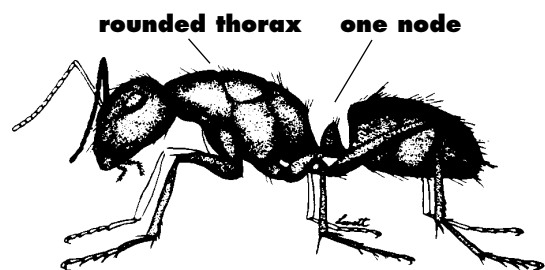

Most other ants look like this.

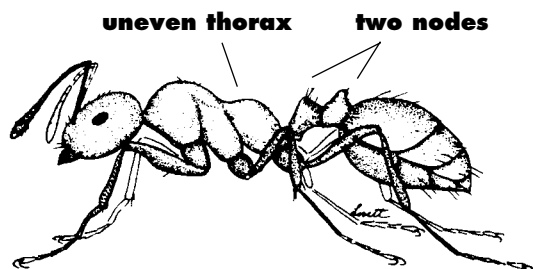

Winged ant



Termite

Beaded, straight antennae, no waist



How to find the nest

To find an indoor nest, look for the most ant activity. Carpenter ants are most active between 8 p.m. and 4 a.m.

If you don't see a pattern in their activity, consider placing food such as honey or canned cat food on a plate. Once the workers find the food, they should show you a pattern as they bring it back to the nest.

Indoor ant colonies are often under tubs, around sinks and toilets, in poorly ventilated attics, in leaky roofs or in rotting window sills or door frames.

Getting rid of carpenter ants

Indoor treatment

Once you find the nest, solving the moisture problem and removing damaged wood often removes the ants.

If you decide to use a pesticide, use it only in suspected nesting areas. Using foggers or treating exposed surfaces where you see ants will not solve the problem.

Outdoor treatment

You can spot-treat indoor satellite colonies. But if the ants are a long-standing problem, a more permanent solution is to find and treat the parent colony. Check wooden porches, landscape timbers, and old stumps for the main colony.

Do you need professional help?

If you decide you want professional help, contact two or three reputable firms. Ask them about their service. Compare cost, guarantees, and type of treatment. If done correctly, a single spot treatment of the nest should solve the problem.

Adapted with permission from *Controlling Carpenter Ants* A3641, by Phillip J. Pellitteri, distinguished outreach specialist in entomology, UW-Extension, and Insect Diagnostic Lab, UW-Madison (Madison, Wis.: Cooperative Extension Publications), 1995.

Illustrations from *Controlling Ants* A1970 by W.L. Gojmerac, UW-Extension, 1990.

Prepared by John Merrill, extension housing specialist, UW-Madison.

Home Wise

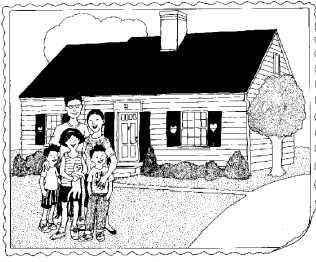

Termite control

Why worry about termites?

Termites wreak far more damage to buildings than any other insect species. Annual cost for prevention and replacement of destruction from termites is estimated to be close to \$1 billion nationally.

Termites can be grouped into four categories:

- Subterranean
- Dry wood
- Damp wood
- Powder post

Subterranean termites are the most destructive and the type common in the Midwest. They enter structural wood through wood that touches the soil, cracks in concrete slabs, over the edge of slabs, through expansion joints, openings around plumbing and masonry or concrete-block footings.

Subterranean termites eat the softer interior parts of wood. Thus, there is often no visible trace of damage. Damage is not rapid. However, if left undisturbed for several years, termites destroy large areas of wood.

How to find out if you have a termite infestation

A sure sign of infestation is earthen “shelter tubes” on foundations, walls, bath traps and wood. To check for termites, probe any wood near the foundation or soil with an ice pick or sharp screwdriver.

Termite-damaged wood offers little resistance to the probe, and the pointed tool will sink easily into wood. Swarming termites indoors are a sure sign of infestation.

How to control termites

To prevent potential termite invasion...

1. Remove construction waste, tree stumps, grade stakes and other wood from the building site.
2. Repair structural defects that keep wood moist.
3. Create termite barriers — mechanical or chemical.

Termite life cycle

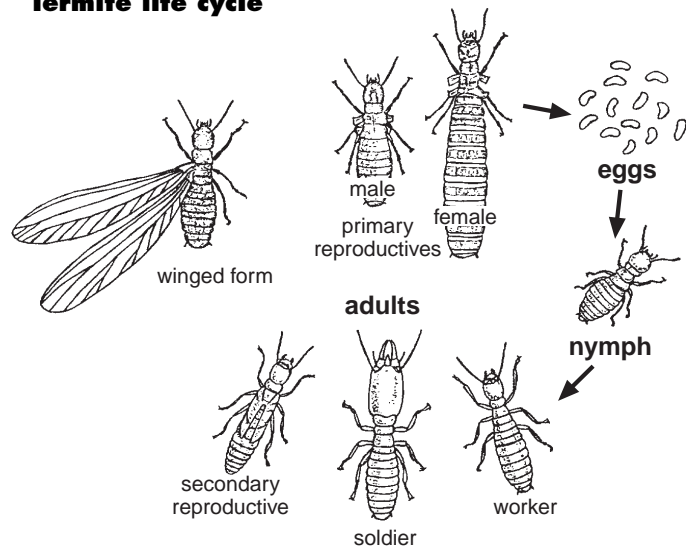

Pretreating the soil below the home before construction is relatively inexpensive and usually the preferred method.

There are two choices for **chemical treatments**. The most common method used during the last 40 years is to create a **pesticide barrier** around the foundation of the home. Specialized equipment, restricted chemicals and a good understanding of termite biology are needed for proper termiticide application, and should be done by a certified pest control operator.

A second choice is to use special **termite baits**. Termites will feed on these toxic materials and share with other members of the colony. Baiting systems use less toxic and much smaller amounts of chemicals. Baiting is slower and usually more expensive but less intrusive than chemical barriers. You should still seek professional help for this type of treatment.

Termiticides are potentially toxic to people and other warm-blooded animals and must be handled with care. Keep children and pets away from termiticide preparation and application sites.

Do not treat soil beneath structures that contain cisterns or wells, or soil saturated with water or frozen.

Keep watch for termites

In terms of maintenance, make regular inspections. Keep water and vegetation away from buildings and do not disturb chemical ground treatments.

References:

- Houseman, R. (2000). State Entomology Specialist, University of Missouri. Personal Communication.
- Meder, Stephen and Botsai, Elmer (2000). Treating termites right. *Home Energy*, July/August, 24-30.
- Sanders, Darryl (1996). *Termites*, M.U. Guidesheet (G7420), Entomology Department, University of Missouri Extension.

Prepared by Atiya Mahmood, former housing specialist, University of Missouri-Extension.

Home Wise

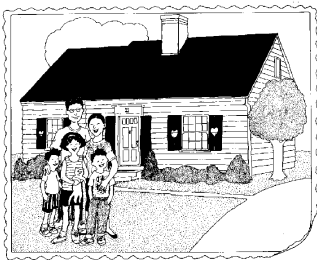

Roach control

Why worry about cockroaches?

Some people worry that cockroaches carry diseases. This isn't usually true. However, they can contaminate food as well as cause damage to food, wiring and other items in your house. They also contribute to allergies.

Why do I have roaches?

Roaches enter homes in food and other containers, or from a house or apartment that shares a wall with yours. Roaches are typically about half an inch long and light brown, with two dark streaks behind their heads. Young roaches are smaller and darker, with a light streak on their back. Roaches live in kitchens where food is available. They need moisture, so you often see them near toilets, sinks and pipes.

How can I avoid bringing roaches with me from our old house?

To leave roaches behind, pack everything in your kitchen and bathroom in new boxes, and piece by piece. Inspect each piece for hitchhiking roaches. For items like toasters that you can't fully inspect, place them in the freezer over night. While roaches can survive cold, they can't survive thermal shock — sudden temperature changes.

Once you have packed a box, take it immediately out of the room, and out of the house if possible. If this isn't possible, keep boxes off floors and away from walls.

As an extra protection, consider using a roach spray inside the kitchen and bathroom cabinets of your new home. Concentrate on cracks, joints and holes.

How can I keep roaches out of my house?

- **Don't bring cockroaches in.** If you live in a single-family house, roaches will only get in as hitchhikers on items you bring into the house. Check all containers — particularly beverage cartons — for roaches and egg cases. Egg cases are dark colored, and vary in size from a split pea to a kidney bean.
- **Don't feed roaches.** Don't leave open containers of food or beverages around. This includes pet food. Don't leave dirty dishes around over night. Take garbage out every evening. Repair leaky faucets and pipes.

How to get rid of roaches

First, be sure you are not feeding roaches. Insecticide treatments are effective only if cooking and eating areas are clean and roaches cannot find food — or pet food.

Use roach traps to find where roaches are living. Place traps in several locations tightly against walls. Then check to see which traps collect the most roaches, and apply insecticides near those traps. (With any insecticide, follow label directions.)

If you choose to use roach spray or powder, place it in cracks, along baseboards, on the floor behind stoves and refrigerators, and other places with high roach traffic. It is not effective to treat shelves and counter surfaces.

Roach baits are effective if you place them near where roaches are hiding. Do not spray near the baits.

These four cockroaches are found in Wisconsin.

Oriental

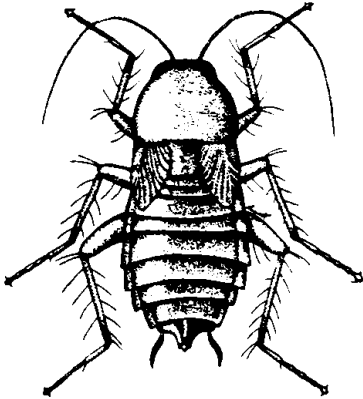

German



Brown-banded

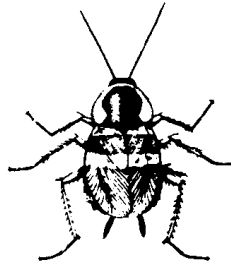

American

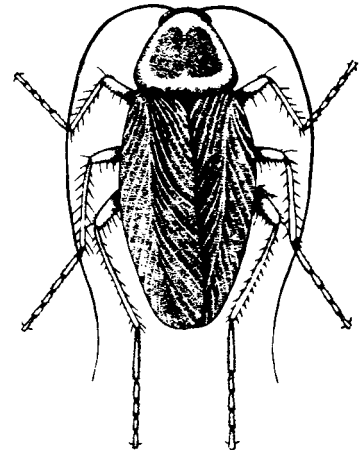

Insects appear approximately 1½ times their actual size.

Adapted with permission from:

Cockroaches AG-F0-1003-B by Jeffrey Hahn and Mark Ascerno, (St. Paul, Minn.: Minnesota Extension Service), Revised 1991.

Controlling Cockroaches A1953 by W.L. Gojmerac (Madison, Wis.: University of Wisconsin-Extension), Revised 1985.

Illustration courtesy of Lee Lovett, Wisconsin Department of Agriculture, Trade and Consumer Protection, from A1953.

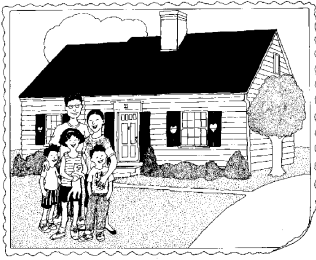

Faucet aerator care

What is a faucet aerator?

There is a part of most faucets you probably take for granted. It is called an aerator. This helps increase the water pressure at the faucet, and helps direct the flow.

How do I know if the aerator is not working?

If you have a faucet with very little water coming out when you think there should be more — or if water runs unevenly — it may be because the aerator is clogged.

To clean an aerator...

- **Block the sink drain,** so you won't lose any parts.
- **Unscrew the aerator** from the end of the faucet spout. To do this, wrap a dry cloth around the aerator and twist to the left. **DO NOT** use pliers, because they will scratch the spout.

- **Keep parts in order.** The aerator has several parts. When you remove them, be careful to keep them in order so you can put the aerator back together again.
- **Remove dirt** from the various parts, and rinse them clean. Soak encrusted parts in vinegar to remove hard water deposits.
- **Reassemble the parts,** twist the aerator back onto the spout, and tighten it without tools. The rubber washer should keep the aerator from leaking. If the faucet leaks, you may have misthreaded the aerator, or not reassembled it properly. Try reinstalling it, rather than using a pliers to tighten it.

Aerator

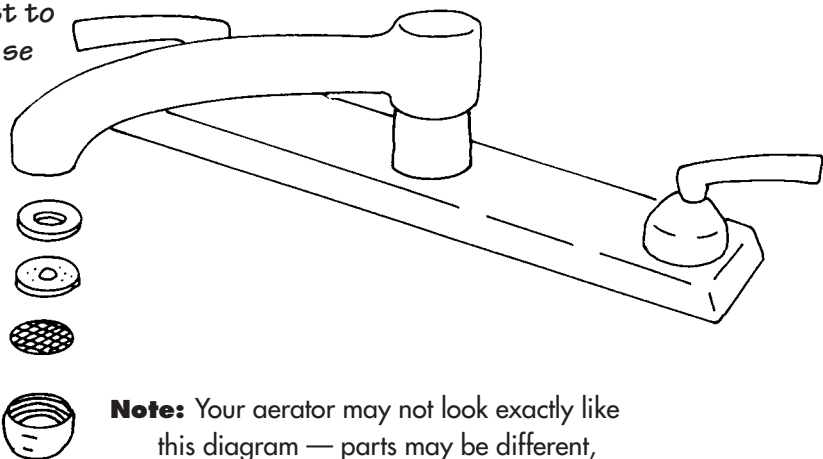

Note: Your aerator may not look exactly like this diagram — parts may be different, or in different order.

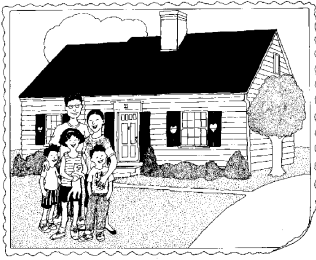

Garbage disposal care

Using your garbage disposal

Here are some ways to keep your disposal unit working properly:

- **Keep hard objects out.** This includes plastic, rubber and metal, as well as bones and gristle — unless the owner's manual says your unit can safely dispose of those items.
- **Use a strong flow of cold water** when grinding waste. Cold water will help harden grease, so it doesn't clog the disposal unit or drain line. Water flow will make sure the ground up waste passes into the sewer and doesn't clog your drain lines.
- **Leave the water running for a few seconds after** the disposal finishes grinding, to flush the drain.
- **DO NOT** let food stand in the disposal. This causes the interior to corrode and can produce odors.
- **If a disposal seems to take a long time to grind food** — The grinding lugs may be coated with soft food and not rotating. Try grinding chicken bones or peach pits to clean the soft food off the grinders. Ice cubes are too soft to do the job.
- **DO NOT** use chemical drain cleaners in the garbage disposal. Follow the steps above to prevent clogging. To unclog a disposal unit, see the following ideas.

What to do...

If the disposal stops:

This usually means something is jammed in the disposal unit.

If the motor is humming:

- Turn the disposal unit off.
- Turn the cold water on.
- If your model comes with a wrench, insert it in the hole in the bottom. Turn the wrench back and forth until the disposal grinders turn easily.

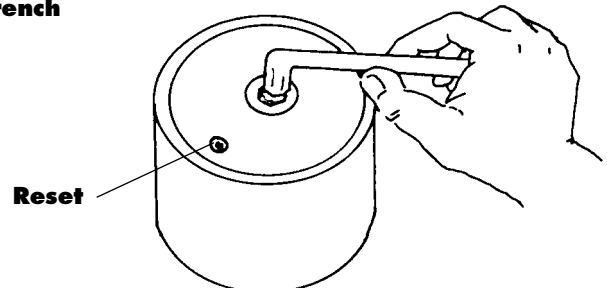
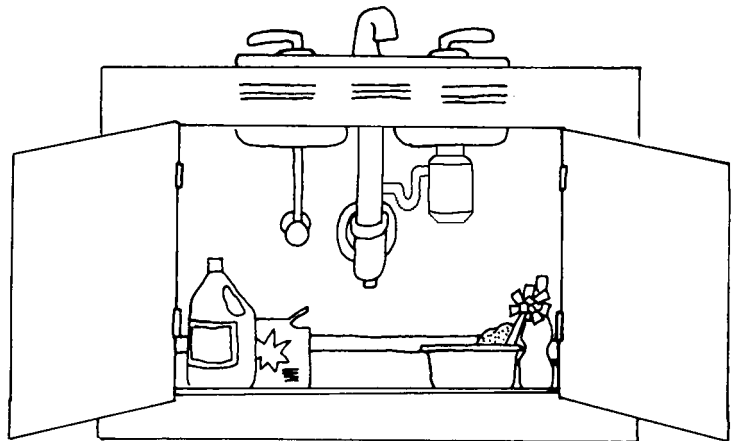

- If you can't use a wrench, take a wooden stick — such as a wooden spoon or section of broom handle — and push it into the disposal from above. Push against one of the grinders until they turn freely. **NEVER** put your hand in the disposal.

Once you've removed the jam and the grinders turn easily, turn the disposal unit on again.

If the motor is not humming:

- Press the reset button on the bottom of garbage disposal. If this doesn't work, wait a few minutes and try again.

If the disposal is noisy:

This usually means some hard object like a spoon or bone has fallen into the garbage disposal.

- Turn off the disposal unit.
- Use a long-handled tongs or pliers to reach into the disposal and remove the object. **NEVER** put your hand in the disposal.

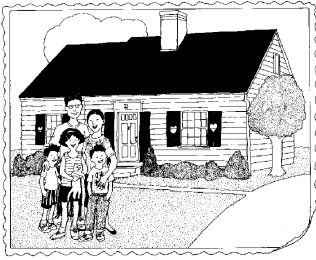

Unplugging sink drains

How do drains work?

When water runs down the sink drain, it flows through a trap (see diagram). The trap is designed to prevent objects such as jewelry from getting into the sewer system. The trap also prevents sewer odors from getting into the house by “trapping” a little water in the drain.

If the drain backs up suddenly, something may have fallen into the drain. If drainage slows gradually, then the cause may be a buildup of hair and grease.

Steps to unplugging a drain

1. If you can, remove the stopper and clean it. If not, use a piece of stiff wire with a bend at the end, or a toothbrush, to remove hair and soap scum.
2. Pour boiling water down the drain. This may dissolve soap scum that could be plugging the drain.
3. Try a plunger (plumber's helper):
 - Fill the sink half full of water.
 - Plug the overflow hole at the top of the basin with a wet rag or rubber ball (see diagram).
 - Put the plunger over the drain, and work it up and down several times.
 - Quickly lift the plunger away from the drain.
 - If drainage improves, turn the faucets on full force to finish clearing the plug.

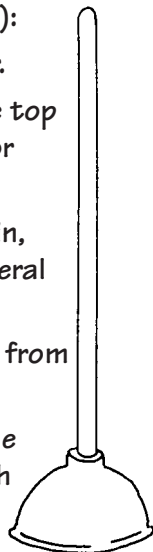

4. If the plunger does not work, you can remove the trap.
 - Place a pan under the trap.
 - Loosen the nuts connecting the trap to the sink and to the drain.
 - Remove the end of the trap from the sink first.
 - Clean the trap with a wire and a rag. A clothes hanger is a good source of wire.
 - Replace the trap. Be sure:
 - Both gaskets are in place.
 - Nuts are threaded straight.
 - All connections are tight.
 - Check for leaks by running water through the drain.

5. If you use chemical drain cleaners, take extreme care and follow label directions. If drain cleaners don't work, they leave harmful chemicals in the water that backs up in the sink. They can also be dangerous poisons to store when children are in the house.

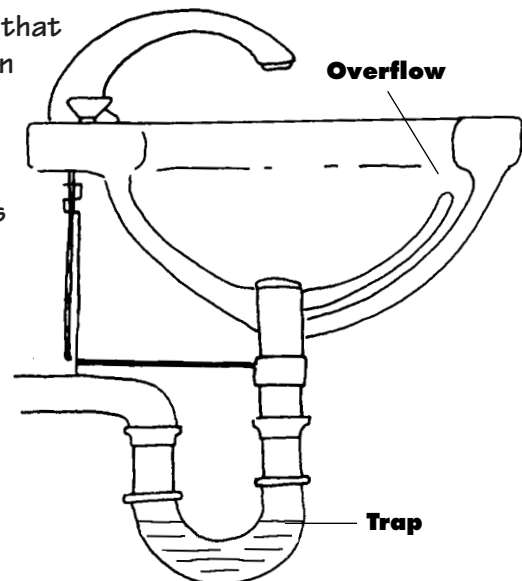

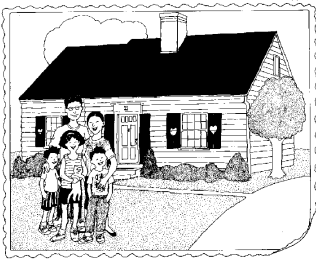

Unplugging toilets

What if flushing the toilet fills the bowl?

If water won't drain from a toilet, wait a few minutes to see if the water level goes down. The level will often drop somewhat, even when the outlet is plugged. If the water level does drop, it will be easier to work on the problem.

While you are waiting, find out what is plugging the toilet.

Steps to unplugging a toilet

Soft objects

If you can wait an hour or two, toilet paper and human wastes will dissolve and take care of themselves. To speed the process, use a plunger. The type shaped like a ball works best.

1. Place plunger over toilet outlet, and push it up and down several times.
2. Next, quickly pull the plunger away from the outlet. This pulls blockage back into toilet bowl.
3. When finished, wash the plunger.

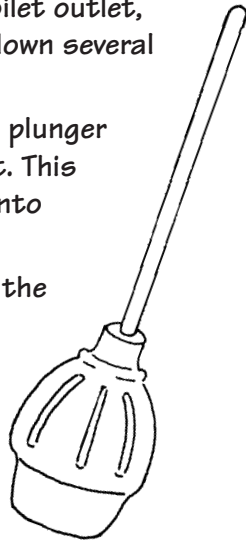

Hard objects

Remove hard objects such as hair brushes as follows:

1. Form a hook at the end of a piece of heavy wire. A clothes hanger is a good source of wire.
2. Push the hook up into the toilet outlet (see diagram).
3. Hook the object, and remove it.

If this doesn't work:

4. Tie a plastic bag over your hand.
5. Reach into the outlet and remove the object.

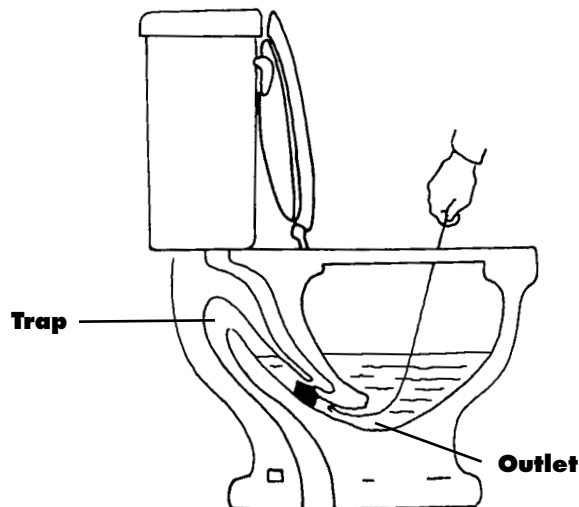

Home Wise

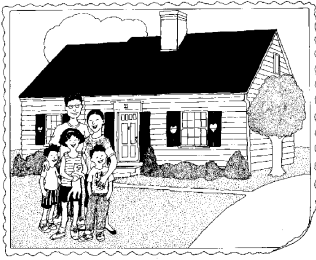

Electrical circuit breakers

What do electrical circuit breakers do?

If an appliance breaks or draws too much electricity, a circuit breaker trips and prevents more electricity from going to the appliance. This protects you from shock, and your home from fire.

If you want to work on a light or an outlet, you can use the circuit breaker to shut off the electricity to that part of the house so you can work in safety from shock.

Each circuit has a number beside it. Inside the circuit box door, you should find a list of the rooms or appliances each circuit protects. If you do not find one, consider making a list by turning off circuits one by one, and writing down which lights, outlets and appliances go out.

What if a circuit breaker is tripped?

If any electrical outlet does not work, the circuit breaker may have tripped. You can tell which one is tripped by looking at the breakers and seeing one that is not in the same position as the others. If one is between on and off, that one has been tripped.

To reset the circuit breaker, first press the breaker switch all the way to the off position, then press it back into the on position. If a breaker refuses to stay on, disconnect any appliances connected to it and try again. If the circuit breaker now stays on, then one of the appliances may be broken.

Circuit breakers may also be tripped if you use too many appliances on a circuit. For example, using a toaster and a waffle iron at the same time might overload a circuit.

If the circuit breaker still goes off when no appliances are plugged in, the circuit breaker is broken — call an electrician.

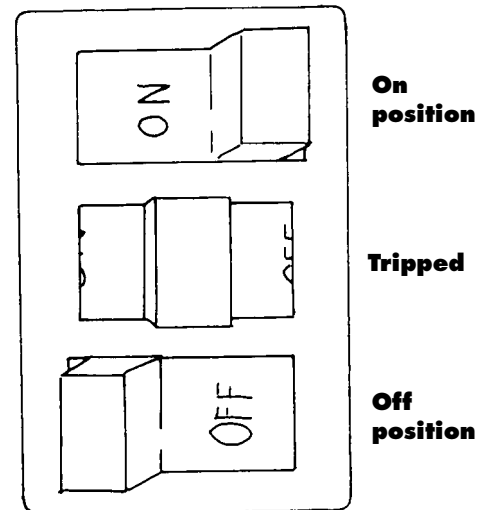
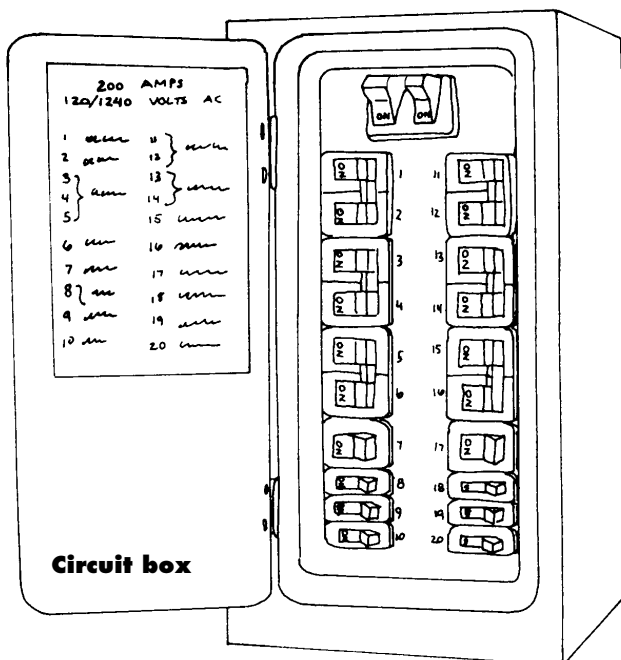

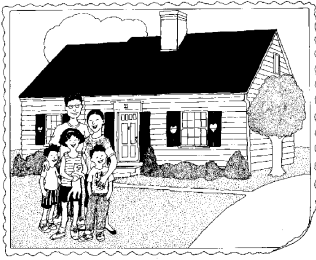

Ground fault circuit interrupter

What is a ground fault circuit interrupter?

A ground fault circuit interrupter (GFI) is a special electrical outlet that prevents electrical shocks in such areas as bathrooms and kitchens, where you are likely to be in contact with water and electricity at the same time. Unlike a normal circuit breaker, this is sensitive to very small amounts of electrical leakage. In new homes, they are required in bathrooms, kitchens and outdoors.

How do I use one?

You use a ground fault circuit interrupter just like any other electrical outlet. Plug in an appliance such as a clock. Push the test button to make sure the circuit will be interrupted if electricity leaks — the clock should stop. Then press the reset button.

What if this outlet does not work?

This outlet can shut off if room humidity is high, or the electrical connection is damp. First, remove the appliance that did not work when you plugged it in, and try another appliance. If the outlet still does not work, press the reset button.

If you try this several times and the outlet still doesn't work, check the circuit breaker in your electrical service box. See *Wiring: Electrical circuit breakers*. If the circuit breaker is still on, you may need to have the ground fault outlet replaced.

Sometimes, more than one outlet is wired to one GFI. If another outlet fails, check nearby GFIs. If nearby GFIs are fine, check the circuit breaker.

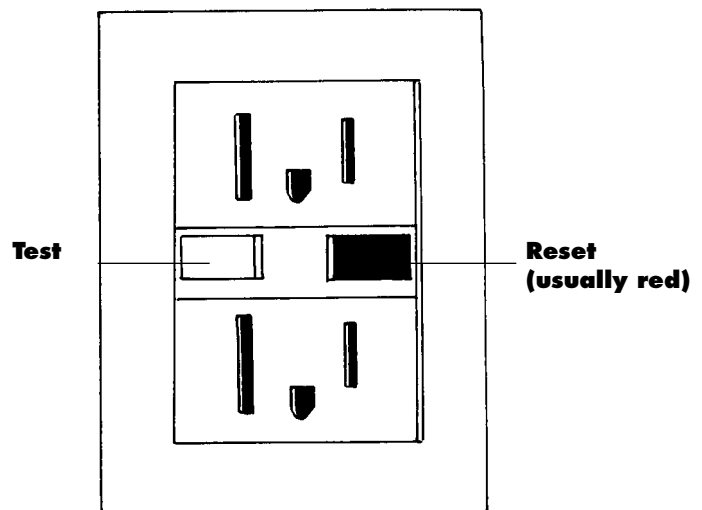

Home Wise

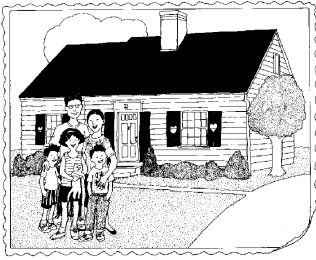

Home safety

John Merrill, Kim Terry and Rosalie Powell

II. Home Safety Fact Sheets

Smoke & carbon monoxide detectors	49
Lead paint hazards	51
Living with neighbors	55

Add your own home safety information to this section.

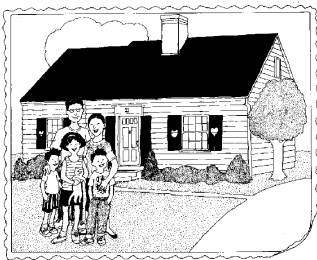

Smoke and carbon monoxide detectors

How does your smoke detector work?

- **Battery-powered models** — These are powered by a battery that you should replace every year, preferably with an alkaline type. Be sure batteries are always in place and powered. Each detector operates independently. Consult the use and care manual.
- **Hard-wired models** — These are connected to the house's electrical system, just like your lights. All the alarms are connected so if one sounds, the others will sound as well. They do not need batteries. However, they may not work if the electricity is turned off or interrupted.

What if you burn the toast?

If you create smoke while cooking and the alarm sounds, open a window or door and run the kitchen fan until the smoke is cleared from the smoke detector. Fanning air through the detector will help the smoke to clear faster.



How can you test the alarm?

Check your smoke detectors once a month to be sure they are working. Put a reminder on your calendar.

First, check that the red light is blinking about once a minute. Next, test the alarm by pressing the test button firmly for five (5) seconds. The alarm will sound. The noise will stop when you stop pressing the button. (See diagram.)

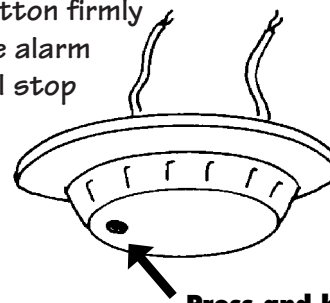

Press and hold

If your smoke detectors run on batteries and you've been away from home or on vacation for a week or more, test the alarms when you return.

You can also test by blowing smoke directly into the smoke detector. Never use a flame near the smoke detector; you may damage the detector.

What if an alarm does not work?

If the alarm does not sound when you test it — and the battery is charged — check the use and care manual that came with your smoke detector.

If you've tried everything and the alarm still doesn't work — replace the smoke detector as soon as possible.

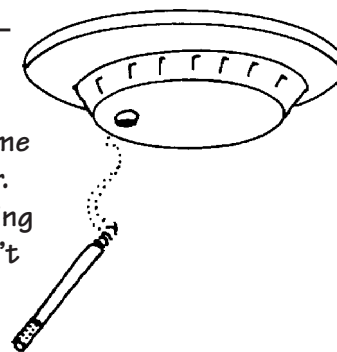

Carbon monoxide — A winter concern

When the home is closed and the heating system is operating, carbon monoxide poisoning is a concern. This is the number one cause of accidental poisoning in the United States.

This is particularly dangerous because it gives no warning. **Carbon monoxide** is an odorless, colorless product of incomplete combustion, and spreads rapidly. Early symptoms are easily mistaken for the flu and ignored.

Any combustion appliance can be a source, from the central heating system to a space heater or fireplace, even a vehicle left running in an attached garage.

To avoid danger...

- **Have your heating system checked regularly by a technician.**
- **Avoid using unvented combustion appliances for heating, such as ovens.**

Gas stoves may generate small amounts of carbon monoxide. But unless they are used for long periods of time for space heating, they are unlikely to pose a risk.

- **Install a carbon monoxide detector.**

These sense when carbon monoxide levels reach a danger point and sound an alarm. When buying a carbon monoxide (CO) detector, look for one that has a Underwriters Laboratory (UL) seal. Follow package directions for placement and care.

Early CO detectors were plagued with nuisance alarms. Current models have been redesigned to eliminate this problem.

Reference:

Consumer Product Safety Commission. *Carbon Monoxide Questions and Answers*, CPSC Document #466, www.cpsc.gov/cpsc/pub/pubs/466.html

Home Wise

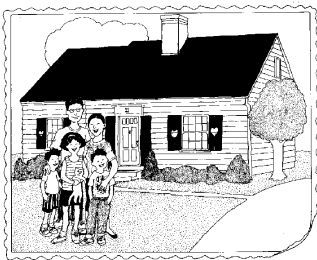

Lead paint hazards

Planning to remodel or repaint? Be careful when you disturb paint in an older house — that paint may contain lead.

The older the house, the more likely it is to have lead paint. When lead paint is damaged by water, sunlight, friction or remodeling activity, the lead breaks into smaller pieces and dust. Young children can be poisoned if they play in these environments.

When you bought your home, did you get a brochure about lead paint? Since 1996, federal law has required property owners to give a brochure called “Protect Your Family from Lead in Your Home” to people who buy or rent a house built before 1978. Since 1999, commercial contractors and painters also must give out this brochure when they disturb more than 2 square feet of paint in a home built before 1978.

Lead poisoning is a serious threat to children under age 6.

Children with traces of lead in their blood can have learning difficulties. Lead is particularly serious for young children for three reasons: behavior, absorption and vulnerability.

Behavior — Young children crawl and play on the ground where lead dust accumulates, and often put their hands in their mouths — especially when they are teething. This behavior brings them into contact with lead dust.

Absorption — Children absorb more of the lead that gets into their stomachs than do adults.

Vulnerability — Children’s brains are especially vulnerable to damage from lead. Lead affects their developing nervous system and can permanently impair intelligence, motor control, hearing and learning.

Lead poisoning cannot be cured, only prevented. Protect young children from exposure to lead paint and dust. And protect yourself. Adults exposed to lead can become irritable, and can have damage to kidneys, sperm cells, developing fetuses and the nervous system.

What if you hire someone to do the job?

If you hire someone to paint, repair or remodel and the job requires disturbing more than 2 square feet of paint on a home built before 1978, contractors must:

- Give the occupant a copy of *Protect Your Family from Lead in Your Home* and
- Get a receipt for this pamphlet.

For a copy of the pamphlet, call the National Lead Information Center (NLIC) toll-free:

(800) 424-LEAD

Or order it via the Web at:

www.epa.gov/lead/nlic.htm

This notification is required by federal law. The rule does not require lead paint removal. It is intended to make you aware of the potential risks so you can decide what to do.

The federal government is taking lead poisoning seriously because 4 percent of children (one in 23 children) under age 6 have elevated blood lead levels.

What if you do the job yourself?

The federal rule does not apply to work:

- you do on your own home or
- involving an emergency repair required
 - to prevent damage to the structure or
 - for safety or health purposes.

If you do your own painting or renovation work, take potential lead paint hazards seriously. Take care to control lead dust and chips created when scraping surfaces for repainting. Clean up all dust and debris before children are exposed. One-day courses, accredited by the Wisconsin Department of Health and Family Services, are available to teach you how to work safely with lead paint. Call 608-261-6876 for a list of training providers with accredited courses.

If your home was built before 1978, you may want to find out where the lead paint is before you start renovating. You can hire someone to test the surfaces in your home for lead paint. Some inspectors have equipment that allows them to check for lead without disturbing the paint. If they check your entire house, you will know if you have lead paint and where it is.

Call 608-261-6876 for a list of certified companies with certified lead inspectors or risk assessors who can tell you where lead paint is located. Certified risk assessors also can advise you what to do with lead paint.

Do-it-yourself lead testing kits such as “Lead-Check” swabs are available, but they provide only limited information. They don’t tell you how much lead is present.

Taking paint samples to send to a laboratory for analysis is another option. Samples should include all layers of paint. Different walls or woodwork may have different underlying paints. One sample in a room may not give you the complete picture. For an updated list of laboratories NLLAP-accredited to analyze environmental lead samples, call 1-800-424-LEAD or go to the Web listing at:

www.leadlisting.org

For projects that disturb large amounts of lead paint, you may want to hire contractors who have been trained to work safely with lead paint. Call 608-261-6876 for a list of certified companies with certified lead hazard reduction staff.

Can you protect yourself and your family? Yes!

Maintaining lead-based paint requires extra care to minimize harmful dust and to carefully contain and clean up the dust created by repainting. Untrained owners trying to remove lead-based paint may poison their children by mistake.

Fortunately, information is available about lead paint hazards and how to deal with them. The National Lead Information Center offers other publications including *Lead Paint Safety: A Field Guide for Painting, Home Maintenance and Renovation Work* and *Lead in Your Home: A Parent’s Reference Guide*.

You can order these from 1-800-424-LEAD or on the Web at:

www.epa.gov/lead

You can get “Lead Paint Safety, A Field Guide...” from:

www.hud.gov/lea

Look out for lead

WHERE TO LOOK:

Lead is commonly found in homes built before 1978. Look in these areas.

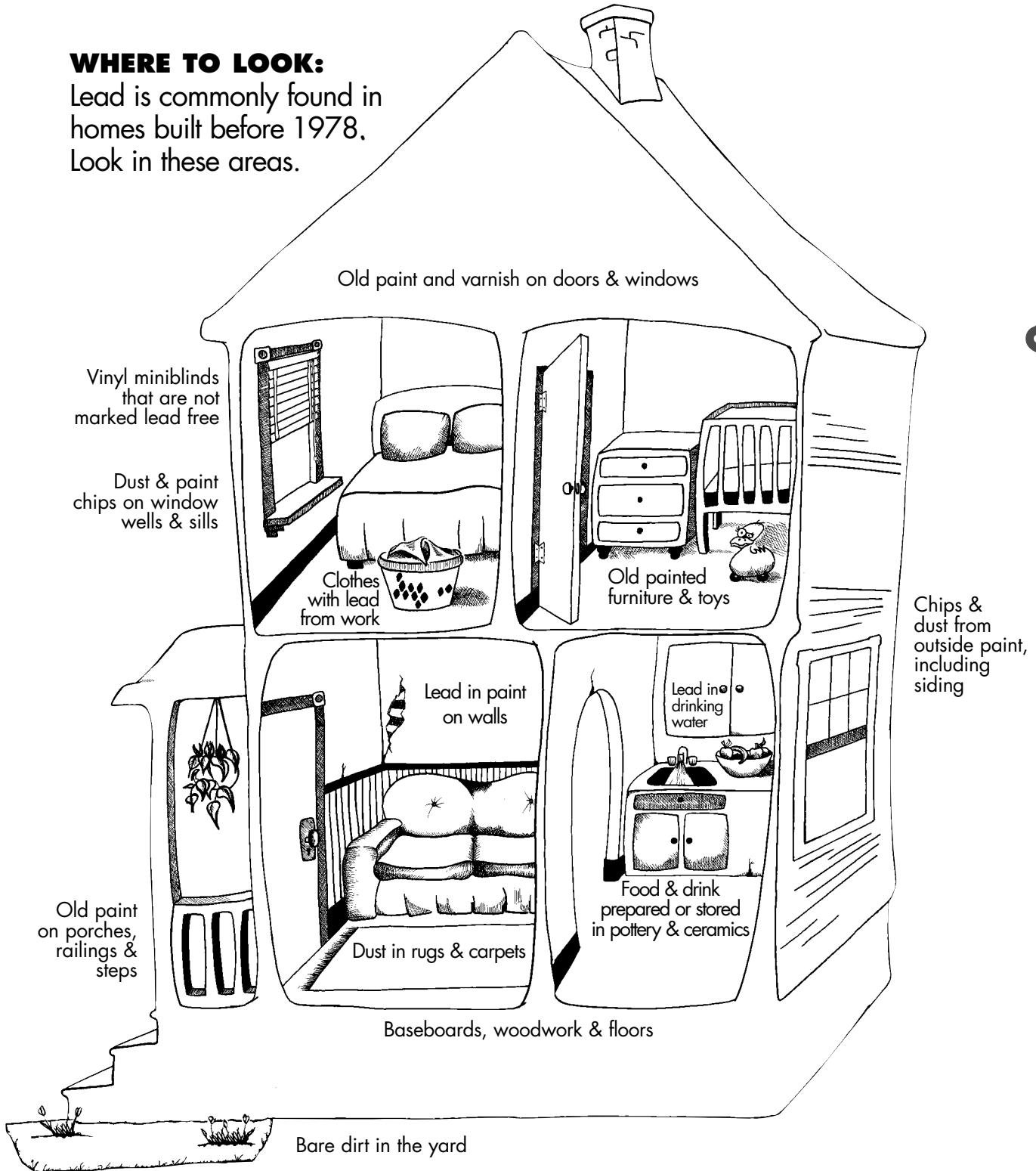

If you do not have a computer, try your local library. Most libraries have a computer connected with the Internet. Libraries in Wisconsin also have access to copies of "Maintaining a Lead Safe Home" by Dennis Livingston, a book that has excellent advice for owners and families.

You may be able to get financial help for controlling lead paint hazards on your property. For a list of funding sources, call your local health department or:
(608) 266-5817

Illustration courtesy of the Wisconsin Childhood Lead Poisoning Prevention Program, Wisconsin Department of Health and Family Services Division of Public Health.

Prepared by John Merrill, extension housing specialist, UW-Madison, and staff of Wisconsin Department of Health and Family Services Division of Public Health.

Home Wise

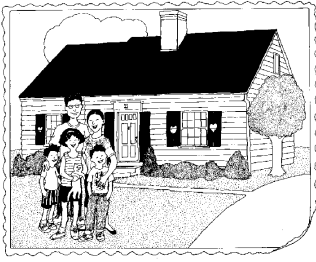

Living with neighbors

Your neighbors can be valuable resources. How well do you know them?

You've heard the saying "Your home is your castle." Like a castle, a home can provide privacy and space you can control. However, families who lived in castles had their problems.

In the old days, castles were built to keep out robbers and attackers. The nearest neighbors were miles away, and probably enemies. Fortification kept lawlessness outside the castle walls.

In some communities today, homeowners are still acting as if they live in the Middle Ages. They are fortifying their homes like castles with security fences, window grates, and multiple locks — abandoning their neighborhoods, thus encouraging lawlessness.

In some cases, homeowners are stressing control and privacy to extremes. They are acting as if they have the right to do whatever they wish with their house and land without regard for their neighbors.

We are much more likely to enjoy the security we want if we work with our neighbors. While you may not become best friends, getting to know your neighbors has many advantages.

Connecting with neighbors

Knowing your neighbors can make your home more than a castle.

Children often are the first to get to know their neighbors in the course of play or school. They provide a natural way for you to meet other parents.

If you do not have children living in your home, making contact with neighbors may take more effort. Most of us are so busy that unless we make a deliberate effort, we deny ourselves the benefits of getting to know our neighbors.

Here are some ways you can get to know your neighbors.

■ **When you move in, introduce yourself to neighbors.**

Let them know that if something that you or your children do — or neglect to do — ever bothers them, you hope they will talk to you about it. Assure them that you want to be good neighbors and that you need to know if they have concerns.

■ **Invite your neighbors to an open house.**

In summer, consider a potluck picnic in the backyard.



- **Join neighborhood or block groups.**

Some cities have neighborhood groups. These do a variety of things to improve the neighborhood. Taking part in these activities can be a great way to help the neighborhood and get to know your neighbors at the same time.

- **Spend time in your yard and your neighborhood.**

If you are doing yard work, people may be interested in what you are doing and stop to talk. Take walks after dinner and take the chance to talk with neighbors who are in their yards. Look for community garden plots. Visit these in the evening or weekends to meet local gardeners.

Neighbors can:

- **Offer advice about your home and local services.** They may know some of your home's history. They may recommend someone for repairs or yard work.

- **Provide help when family and close friends are too far away or not available.** They may have tools you can borrow or be willing to lend a hand.

They may have children who can do odd jobs for you — or your children can do odd jobs for them, such as pet care or yard work.

- **Watch out for each other.** If your neighbors know you well enough, they can report anything unusual, roll up your car windows when it rains, or return your stray pet.

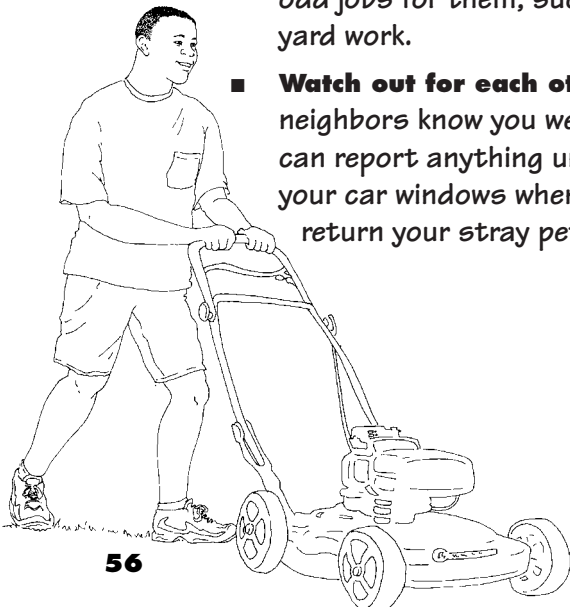

- **Work together on issues that concern you all.** You can team up to stop speeding vehicles or deal with a neighbor who is creating problems for everyone, and address other neighborhood issues.

Preventing crime

You and your neighbors clearly share two important concerns — preventing crime and maintaining property values.

Most residential crime is opportunistic. In other words, criminals commit crimes because they see an easy opportunity. For example, they see a home with several newspapers on the front porch, no evidence that anyone is home, and no neighbors about. They check further and find an easily forced door or an unlocked window.

Neighbors can help prevent crime.

Watching out for each other can make criminal activity more difficult, since the risk of being caught increases. For the typical residential crime, this can make a huge difference.

Here are four principles of neighborhood crime prevention, and how to put them to work.

1. Improve physical security.

Make sure all outside doors and accessible windows have good locks.

Outside doors should be made of solid wood or clad in steel with 1 inch long deadbolt locks. The inside lock knob should be as far away from adjacent windows as possible.

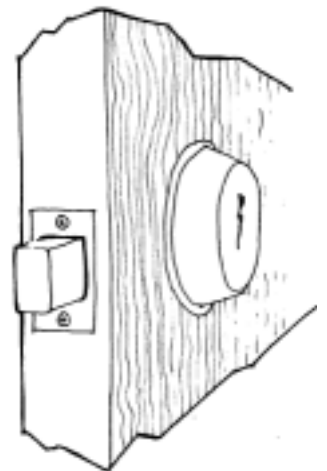

Outside doors should be of solid wood or clad in steel with a 1-inch deadbolt lock away from windows.

Sliding glass doors or windows should have something sturdy blocking the track to keep them from being forced open. Cut a steel bar, broom stick or dowel to fit the track so the door or window can open enough to let in air but not a person.

All accessible windows should have locks. Simple locking devices are available that allow windows to be open a few inches for ventilation.



Window locks allow windows to be open a few inches for ventilation.

2. Keep entry points visible.

Entry points include outside doors, basement windows, and windows accessible from the ground, a porch or fire escape.

Criminals are less likely to try to break into a home if they think their activity will be seen from the street or a neighbor's home. Use outside lights where doorways or windows are shadowed. Keep shrubbery trimmed and low next to the house. It also helps to keep fences low.

3. Do not advertise that you are away.

If you will be away for several days, arrange for a neighbor to take in your mail and newspapers, care for your pet, and water the lawn or shovel the walk.

Leave a light and radio on in a room upstairs or in one not easy to see into from outside. Lights on timers that go on and off at different times are even better. Keep garage doors closed even

when you are home so no one can tell whether your car is in the garage.

4. Work with your neighbors.

For these crime prevention steps to work, neighbors must know each other well enough to recognize suspicious behavior — and be willing to report such behavior to the police.

The police or sheriff's department may be able to help you set up a formal block watch group with regular meetings and special street signs. Watching out for each other can greatly decrease the risk that criminals will try burglary in your neighborhood.

Maintaining property values

Neighbors can affect each other in the wallet as well. In most neighborhoods, the price of houses (market value) remains steady or increases every year. However, in neighborhoods where even a few homeowners neglect their homes and yards, house prices may decline. It can also be harder to sell homes.

Some signs of neglect include neighbors who:

- Do not keep the outside of their house and garage in good repair. For example, they do not replace broken shutters, fix torn screens or repaint badly peeling siding.
- Do not keep the lawn mowed and shrubbery trimmed, or sidewalks cleared.
- Have a yard littered with junk including cars that do not work.

If you are the neighbor who neglects his or her home, you will be causing your neighbors to suffer and may even cause ill feelings toward your family.

The market value of your neglected house usually drops the most. A neglected house is one a criminal may regard as safer to burglarize. And if your neighbors complain about your property to authorities, you may face fines.

If you cannot do the work yourself, this is a good time to call on your neighbors. They may have ideas about who could help, or their children may be able to do some of the work.

See these fact sheets in this manual: *Hiring someone to help with minor repairs* and *Should you do a repair yourself?*

Resolving disputes with neighbors

Sometimes being good neighbors can be hard. People often have different values and attitudes, so disputes are natural. Your skills as a neighbor are revealed by what you do when a conflict occurs.

The concern may be loud parties, kids damaging flowers, or a problem pet.

Here are a few tips on managing conflict.

1. Begin by listing problems, how they impact you and your family, and what you want.

Before you approach your neighbor, you need to be able to clearly state the problems and how they affect you. For example, what problems are loud parties causing you or your family? Do these drown out family dinner conversation, or keep you awake at night so you are too tired at work or school the next day?

2. Approach your neighbor calmly and explain how the situation affects you.

Stay calm. When you are upset, you are likely to raise your voice or call people names. This often causes the other person to become defensive, and the problem worsens.

Use "I" or "we" statements. These are less threatening. For example, try something like this: "When your guests are loud all night, we can't sleep and we feel tired the next day."

Once you have calmly explained how the situation is affecting you, the neighbor may apologize and agree to keep their guests inside and turn down the music.

3. If the neighbors see things differently, listen to their side and try to understand their concerns.

Find areas where you agree. You both may agree that getting your sleep at night is important and that people should be able to entertain their friends in their own home.

4. Suggest different ways of resolving any areas where you disagree, and agree on one thing you are both willing to try.

For example, suggest that they consider closing the windows or turning down their music at a certain time.

Find occasions to talk with these neighbors again soon. Thank them for any changes they have made.

On the other hand, if you fail to come to any agreement, team up with your other neighbors to work out a solution.

Lower the walls, keep the drawbridge down, and work together with your neighbors to create the security you want in your neighborhood.



Home Wise

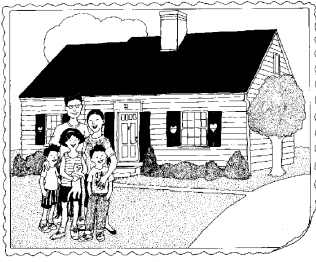

Money management

John Merrill, Kim Terry and Rosalie Powell

Contents

Financial planning

- Emergency fund 61
- Monthly spending planner —
Where does your money go? 63
- Escrow accounts 67
- If you can't pay your bills 69
- Evaluating your insurance needs 71

Home equity

- How much of your home do you own? 75
- Home equity loans 79
- Refinancing your loan? 83
- Protect your home equity 87

Taxes

- Income taxes and homeowners 89
- Property taxes 91
- Sample property tax bill 93

Repair or replace

- How long things last 95
- Should you do a repair yourself? 97
- Hiring a contractor for major repairs
and remodeling 99
- Hiring someone to help with
minor repairs 103

Add your own money management information to this section.

Home Wise

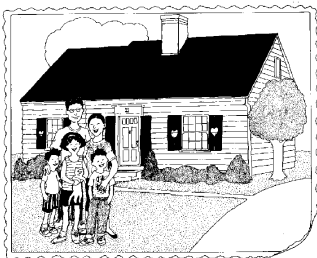

Emergency fund

Why have an emergency fund?

When you were renting, the building owner or management company paid for repairs. As a homeowner, you pay for these things yourself. In 1999, the typical homeowner spent \$670 a year on home maintenance. This doesn't include major repairs such as replacing a water heater or refrigerator. It made little difference whether the home was new or many years old. For an idea of how often you need to make repairs, see *Repair or replace: How long things last* fact sheet.

Chances are you started a savings plan to save money to buy your home. Continuing that savings plan will provide you with an emergency fund to pay for unexpected repairs. Such a fund could also cover your mortgage payment if you miss a paycheck, or have an expensive car repair or trip to the doctor.

Consider the ways an emergency fund can help:

1. You can get repairs done when they are needed, rather than waiting until you can find the money. Waiting may make the problem bigger, and increase cost.
2. If you use the fund to pay the mortgage in an emergency, you avoid late payment fees and a history of late payments with the mortgage lender.
3. You won't have to worry about repaying a loan, and you won't have to pay large amounts for interest.

4. You can select the contractor who will do the best work for the best price, rather than the one who will give credit.

An emergency fund can give you and your family a feeling of security.

How do you set up an emergency fund?

You can set up a separate savings account in a bank or your local credit union, set a savings goal, and add to the account regularly:

- **Start with "new money."** Examples include the bonus you receive at the end of the year, an income tax refund, or the money you had been paying on an auto or other installment loan once you've paid off that loan.
- **Use direct deposits.** Many employers allow you to have all or part of your paycheck deposited directly into a savings or checking account. If you don't see the money, you're less likely to spend it.
- **Add overtime or part-time work.** Consider taking a weekend job or doing optional overtime work. Then earmark that income for your emergency fund. You can stop when you've met your savings goal.

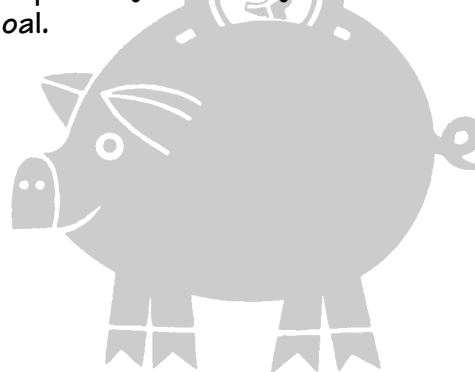

How much should you have in an emergency fund?

Sometimes it is hard to start saving because it seems you cannot save enough. Start with an amount equal to 1 month's mortgage payment. Then add at least 1 percent of the mortgage cost every month. With a \$500 per month mortgage payment, this would be a minimum of \$5 per month. Add more if you can.

Keeping enough money in your home emergency fund to equal 2 to 3 months' living expenses will cover most unexpected expenses.*

It would be wise to continue to:

- Save for other household emergencies and
- Build savings to cover all your living expenses for 2 to 3 months.

*Use the *Monthly spending planner worksheet* to figure this amount.

When should you use your emergency fund?

Use your emergency fund for any service, repair or replacement that you can't pay for out of your current income. Most of the time, these will be expenses over \$100. When you take money out of your emergency fund, remember to replace it, so you have it when you need it. Think of it as a loan to yourself that you repay promptly.

If you are lucky enough not to have an emergency, it might be tempting to use this fund for a special vacation or other large purchase. If you are tempted to spend your emergency fund, remember how hard it was to save that money, and how important your house is to you.

Do you want to risk losing your home by using your emergency fund for something else?

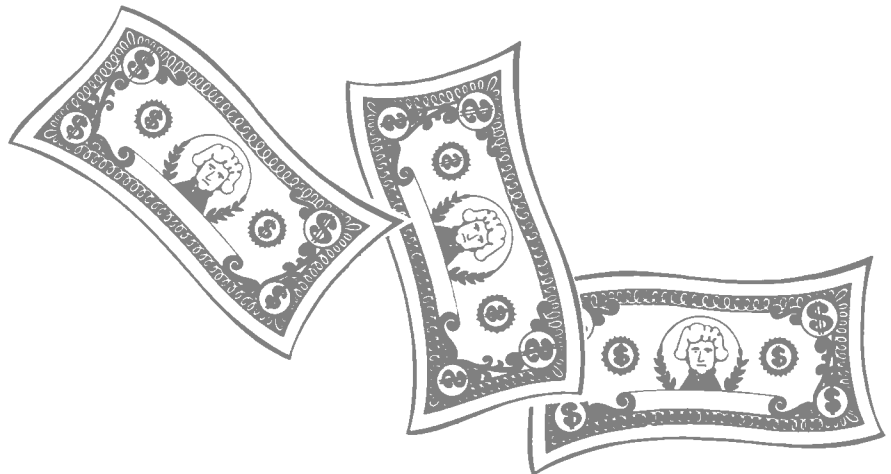

References

Investment Basics B3683, Joyce E. Jones and Linda Boelter, et al (Madison, Wis.: Cooperative Extension Publications), 1999.

Planning to Stay Ahead B3478, Laurie Boyce and Beverly Phillips (Madison, Wis.: Cooperative Extension Publications), 2000.

Survey of Alterations, Additions, Repairs: Maintenance, Repair and Other Work Owner Occupied, U.S. Census Bureau American Housing Survey, 1997: www.census.gov/hhes/housing/ahs/ahs99/ta1-3.html

Prepared by Rosalie Powell, professor and family resource management agent, Milwaukee County UW-Extension; and John Merrill, extension housing specialist, UW-Madison; and Kim Terry, housing and financial management educator, UW-Extension.

R-02

Home Wise

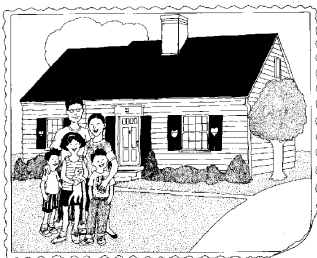

Monthly spending planner—Where does your money go?

1. Monthly income worksheet

Add up **monthly income** for all household members from all sources. If you are paid weekly, bi-weekly or twice a month, multiply by the amount in parentheses (4.33, 2.17 or 2) to get the monthly total.

	TOTAL
Wages, salaries (take-home pay)	
Weekly (x 4.33)	\$ _____
Bi-weekly (x 2.17)	\$ _____
Twice a month (x 2)	\$ _____
Monthly	\$ _____
Other income*	
Tips, commissions or overtime	\$ _____
Child support or alimony	\$ _____
Unemployment Compensation	\$ _____
Investment or interest income	\$ _____
Social Security and pensions	\$ _____
SSI (Supplemental Security Income)	\$ _____
W2 or TANF (Temporary Assistance to Needy Families)	\$ _____
Veterans' benefits	\$ _____
TOTAL MONTHLY INCOME \$ _____	

*Multiply any other income as needed to get monthly amount (by 4.33 if paid weekly, for example).

2. Monthly expenses worksheet

Add **monthly expenses** for everyone in your household.

There are two ways to work out how much you are spending:

- A. Recall expenses.** Put together all costs for the past month, reconstructing your expenses using the checkbook register and receipts. This expense method works best if you make all purchases through a single checking account, and limit the use of "pocket money" and discretionary spending.
- B. Track expenses.** Write down all purchases and payments every day for a month or two. Make sure to record all your spending, including purchases made by check, cash, credit card or direct billing.

Some big expenses such as insurance payments come up only once or twice a year. Others are seasonal, such as school clothes in the fall, income taxes in April, and birthday and holiday gifts. Estimate these expenses on an annual basis and divide by 12 to get a monthly amount.

Housing	TOTAL
Mortgage payment — Including property taxes and homeowners insurance	\$ _____
Equipment, appliances & furniture	\$ _____
House, garden & lawn supplies	\$ _____
Maintenance & repairs	\$ _____
Utilities	
Electric	\$ _____
Gas or oil	\$ _____
Phone — Local	\$ _____
Phone — Other	\$ _____
Waste disposal	\$ _____
Water & sewer or septic	\$ _____
Food	
At home	\$ _____
Away from home	\$ _____
Transportation	
Vehicle payment(s)	\$ _____
Vehicle insurance	\$ _____
Gas & oil	\$ _____
Maintenance & repairs	\$ _____
Public transit	\$ _____
Insurance — if not deducted from your paycheck	
Dental insurance	\$ _____
Health insurance	\$ _____
Liability insurance	\$ _____
Life insurance	\$ _____
Disability	\$ _____

Financial planning

Medical & dental — Not covered by insurance	TOTAL
Co-payments _____	\$ _____
Other _____	\$ _____
Other _____	\$ _____
Credit cards & unsecured loans	
1. _____	\$ _____
2. _____	\$ _____
3. _____	\$ _____
4. _____	\$ _____
5. _____	\$ _____
Other credit _____	\$ _____
Education & recreation	
Education	\$ _____
Movies, rentals & books	\$ _____
Recreation	\$ _____
Cable television	\$ _____
Other _____	\$ _____
Other expenses	
Child care or support	\$ _____
Cigarettes/beer/alcohol	\$ _____
Clothing & personal care	\$ _____
Emergency fund	\$ _____
Lottery tickets & gambling	\$ _____
Savings & investments	\$ _____
Other _____	\$ _____
TOTAL MONTHLY INCOME \$ _____	

3. Compare monthly income and expenses.

Monthly income — Total for all household members from all sources from *Monthly income worksheet*: \$ _____

Monthly expenses — Total for all household members from *Monthly expenses worksheet*: (minus) - \$ _____

Subtract expenses from income.

DIFFERENCE (+) or (-) \$ _____

Date _____

If your total monthly expenses are greater than your total monthly income, you need to make some changes. A family spending and savings plan can help you balance your income and expenses so you come out even each month. This may mean reducing your expenses or increasing your income. You may need to work with creditors to adjust payments to amounts you can afford (see *If you can't pay your bills* fact sheet).

References

Money 2000 and Beyond: Taking Control of Your Spending B3709-2, Patricia M. Swanson and Peggy Nordgren (Madison, Wis.: Cooperative Extension Publications), 1999.

Planning to Stay Ahead B3478, Laurie Boyce and Beverly Phillips (Madison, Wis.: Cooperative Extension Publications), 2000.

Prepared by Rosalie Powell, professor and family resource management agent, Milwaukee County UW-Extension; and John Merrill, extension housing specialist, UW-Madison; and Kim Terry, housing and financial management educator, UW-Extension.

R-02

Home Wise

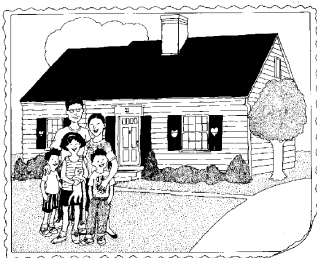

Escrow accounts

What is an escrow account?

Chances are that part of your monthly mortgage payment is set aside in a separate account to pay your property taxes and homeowner's insurance. This account is known as an escrow account.

How much do you pay to an escrow account?

Your monthly escrow payment should be just enough so your lender can pay your property taxes and homeowner's insurance when those are due. However, since tax bills and insurance premiums increase, the government allows lenders to require slightly higher payments. The maximum reserve lenders are allowed to collect is equal to two escrow payments.

If your lender does not set your escrow payment high enough, you may need to pay extra at the end of the year, or your monthly payments will increase the following year.

Federal regulations require lenders to provide an escrow account statement each year, so you know the escrow account balance and how much was spent. You will need this when you pay your income taxes. See *Taxes: Income taxes and homeowners.*

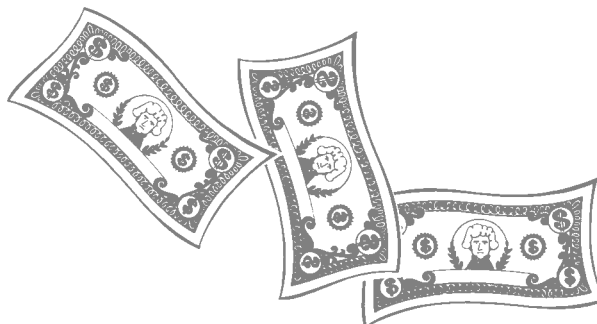

Example

Here is an example of how a lender might figure escrow payments:

Current year property taxes	\$2,400	
Homeowners insurance	+ \$200	
Total	\$2,600	
	Divide by 12	= \$217
Reserve: \$217 x 2 (months) = \$ 434		
	Divide by 12	=+ \$36
Total monthly escrow payment:		\$253



Problems

Several problems sometimes occur with escrow accounts:

- **“Sticker shock”** — A number of homeowners have complained about sudden increases in escrow deposit requirements. This can occur if:
 1. A new company begins servicing your escrow account. The new company may have different escrow practices that may result in a sudden but legal change.
 2. Your lender paid your taxes and insurance on your behalf and there was not enough money in your escrow account to pay in full.

In these cases, the lender advances the payment and makes up the shortage in the following year by increasing the mortgage payment.

Be aware of one-time or limited time increases to your taxes, such as special assessments or other charges. If your escrow analysis is based on such charges that will not occur this year, review your analysis with your lender. It may need to be reevaluated so you will not have a surplus by the end of the year.

- **Overescrowing** — Some lenders may set escrow payments higher than allowed. If your annual account statement shows a balance much larger than needed for anticipated tax and insurance bills, your escrow payments are probably too high. The lender should provide you with a refund if the escrow balance is more than \$50 after taxes and insurance have been paid.

If you believe your lender is not complying with the legal limits to the amount that can be held in your account, you should make a complaint in writing. You have legal and regulatory remedies under the Real Estate Settlement Procedures Act if your dispute is not resolved satisfactorily.

- **Late payment of taxes or insurance premiums** — It is to your benefit to be aware of insurance premium and local tax deadlines. Even if your lender pays these bills from your escrow account you may receive the bill. Unless you can tell from the bill that the original was sent to the lender, it is your responsibility to forward the payment notice to your lender in a timely way.

If you do not receive payment notice, contact the agency that sent the bill and make sure your lender made the payment.



References

FAQs (frequently asked questions) by consumers about escrow accounts (Washington, DC: U.S. Department of Housing and Urban Development), 2000: www.hud.gov/fha/sfh/res/respfaq.html

Financial Department Answers Escrow Questions, Lisa Roys (Madison, Wis.: Wisconsin Department of Financial Institutions, 1998): www.wdfi.org/newsroom/press/pr_escrow_faq.htm

Prepared by John Merrill, extension housing specialist, UW-Madison; and Kim Terry, housing and financial management educator, Milwaukee County UW-Extension.

Home Wise

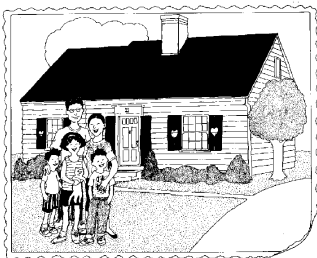

If you can't pay your bills

What happens when you can't pay bills?

If you lose your job or have emergency expenses, you may not have the money to pay all your bills. If this happens, the worst thing you can do is to keep it to yourself and hope no one will notice. Not paying your mortgage or utilities has serious consequences.

Here is what happens if you don't pay your bills.

Mortgage

- **Late fees** will be added to the amount you owe.
- **Your cosigner will be asked to pay.** If a relative or friend cosigned the mortgage, the lender will expect them to make the payments if you do not. Your missed payments could create serious problems for your cosigner as well.
- **Default** — Your mortgage note defines how many missed payments put your loan in default. Being in default means your lender has the right to accept only the full amount due and to limit the time you have to pay in full. You can end up in foreclosure even though you resume making payments.
- **Foreclosure** — Your lender will send you an intent to foreclose letter. If you do not pay as this specifies, the lender will ask the court to sell the property to recover the money owed. If this happens, you could lose your home and the money you have invested in it.

Utilities

- **Interest** may be charged on overdue amounts.
- **Utility service may be shut off.** Utilities such as electric, gas and phone may be shut off.
- **A large reconnection charge** may be difficult to pay later.

So what can you do?

Your lender does not want your home to sell, but would rather have you in the house and making some kind of payments. Similarly, utility companies would prefer not to cut off service to customers.

Take action right away.

At the first sign that you will not be able to make a payment, do the following:

- ✓ **Work out your new income and expenses.** Use the *Monthly spending planner worksheet* to compare your actual monthly income and expenses. This will give you an idea of how much money you'll have to pay creditors.
- ✓ **List your debts.** List debts by the total you owe, including your mortgage. Include the usual monthly payments you make, and the interest charged on the balance.
- ✓ **Work out what you can afford to pay on bills.** Often, being able to pay the interest alone on a bill can help. After living expenses, pay the mortgage and utilities first. Then, divide the rest of your income among the other creditors.

- ✓ **Contact creditors and your lender BEFORE you miss a payment.** Once you have developed your plan, contact your creditors and your mortgage lender. Explain your situation — what has happened and what you expect to happen — and your plan. Often, creditors will negotiate with you for reduced payments. Mortgage lenders and utility companies may have counseling services available to help you figure out realistic payment schedules.
- ✓ **Make specific and realistic offers to creditors.** You will need to talk to someone who can negotiate with you. Often, the first person you talk to is not the person who can negotiate. Be able to offer a specific payment on the billing cycle. Make promises you're able to keep, so you maintain good relations with the creditor. (**Do not** sign an agreement or make promises for a payment plan you cannot meet just to end creditor pressure.)
- ✓ **Follow up with a letter detailing the arrangements you agreed to with the creditor.** This means you need to keep track of names, dates, times, and what you agree to do. Specify the terms of your agreement, the name of the person you talked to, and the date. Keep a copy of the letter for your records, and follow up if necessary.
- ✓ **Stick to a regular bill payment schedule.** Once you have set up a payment schedule with the creditor, it is essential that you make the payments on time. Again, if your circumstances change, contact the creditor **before** you miss or decrease the payment further.
- ✓ **Stop using credit if you can manage.** Use credit for emergencies only. Put those cards away, and deal with cash as much as possible.

Other help in your community

You can get help arranging payment plans by contacting a non-profit consumer credit counseling service in your area. They can work with you to develop a plan for getting control of your bills.

Your county University of Wisconsin-Extension office has programs and publications to help you plan your spending, decrease your debts and increase your savings. See the *Resources* section of this manual.

Adapted with permission from:

Family Finances: Getting by on Less, by Rosalie Powell (Milwaukee, Wis.: University of Wisconsin-Extension), 1995.

Prepared by Kim Terry, housing and financial management educator, UW-Extension. Rosalie Powell was a professor and family resource management agent for Milwaukee County UW-Extension (1995).

R-02

Home Wise

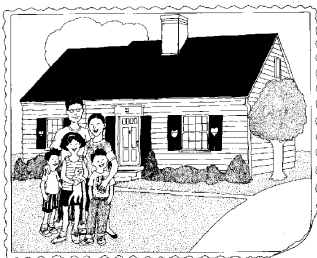

Evaluating your insurance needs

Now that you have become a homeowner, you need to pay attention to insurance for at least three important reasons.

- 1. Insurance can protect your home from physical damage or theft.**
- 2. Insurance can take care of expenses** such as health problems or automobile accidents **that might prevent you from making your house payments.**
- 3. Insurance can protect your home as a financial asset against liability claims.** As a homeowner, your property is an asset that people may try to claim if you owe them money or if they feel you are responsible for causing them harm, for example, in an automobile accident (liability claims).

This fact sheet defines the basic types of insurance and provides ideas on where to look for more information.

Insurance especially for homeowners

Several kinds of insurance are especially for homeowners. These include mortgage insurance, title insurance, homeowner's insurance and flood insurance.

Mortgage insurance

If you bought your home with less than a 20 percent down payment, chances are you are paying **mortgage insurance** as part of your monthly house payment. This insurance is required by the mortgage lender to protect them from the risk that

you won't make your payments. Having this coverage allows you to get a mortgage with a lower down payment.

Private mortgage insurance (PMI)

Unless you have a government-backed mortgage, your mortgage insurance will be through a private mortgage insurance (PMI) company. You don't have to pay mortgage insurance premiums forever. The Homeowners Protection Act of 1998 requires that PMI be cancelled for borrowers with a good payment history when they have repaid 22 percent of the mortgage loan.

However, this law only applies to loans originated after July 29, 1999. Some loans allow you to cancel PMI coverage if your home has appreciated in value so that the loan balance is less than 80 percent of the value of the property. An appraisal may be required to verify the increase in value. Check with your lender about canceling PMI.

Government insured or guaranteed loans

If you have either a Federal Housing Administration (FHA) or a Veteran's Administration (VA) loan, the government protects the lender if you default on the loan. You will pay for this, but it is handled differently than PMI. Talk to your lender if you have questions.

Title insurance

Title insurance protects the **policy holder** from others who may lay claim against the property. This can happen when there is an error in recording the deed or if a missing heir to a previous owner shows up and claims ownership. The company that issues the title insurance will carefully review the records for the property you are buying to be sure there are no apparent problems with the title.

When you purchase your home, the lender will require you to provide title insurance coverage for the loan. In Wisconsin, the seller of the property provides a policy for you as a new owner. Requirements for owners' policies may vary from state to state.

Your title insurance certificate is an important document. You will need it any time you want to borrow against the value of your home.

Homeowner's insurance

Before you purchased your home, you had to show the lender proof that you had purchased homeowner's insurance. This insurance protects you and the lender against loss in the event of damage or theft. It also protects you from liability if someone is injured on your property.

If you do not maintain insurance on your property, your lender will obtain insurance to protect their interest in your property. This "forced place" insurance is more expensive and primarily protects the lender. It is to your benefit to choose the type of insurance on your property rather than letting the lender do so.

Homeowner's insurance comes in different forms. Some policies provide coverage based on **actual cash value**. This means that your payment in case of a claim is based on the current market value of either your home or personal property covered at the time of loss.

For example, if you were making a claim for a television purchased 5 years ago for \$1,000, the actual cash value would be the purchase price minus depreciation. You would be paid about what you could sell your television for today — much less than what it would cost to buy a new television.

Replacement cost coverage will pay you for the total amount that it will cost to replace or repair damaged property. Typically, a replacement cost policy is more expensive. It may be difficult to get replacement cost coverage for older homes where there is a wide disparity between actual cash value and replacement cost.

Flood insurance

Flood damage is not covered in a typical homeowner's insurance policy. If storm sewers often back up or rivers and lakes flood where you live, insurance against flood damage may be important.

Flood insurance is provided by the National Flood Insurance Program, but sold to consumers by state licensed companies' agents and brokers. Some insurance companies also offer their own flood insurance policies in cooperation with the federal government.

Since 1994, mortgage lenders are required to certify whether a property is in a Special Flood Hazard Area, and if so, to require flood insurance as a condition of making the loan. The lender is required to verify that the insurance is in place for the life of the loan.

For more information on flood insurance, contact:

National Flood Insurance Program
P.O. Box 450
Lanham, MD 20706-0459
(800) 611-6123
www.fema.gov/nfip

Other types of insurance

Life insurance

Life insurance provides money to your beneficiaries if you die. Having enough life insurance to pay off the mortgage and other debts can be particularly important if you don't have much savings and your family would have a hard time making ends meet without your income.

Life insurance can be either term or whole life insurance.

Term life insurance provides protection for a specific term — usually 1, 5, 10 or 20 years. The death benefit is paid only if the insured person dies within the period of the contract. In some cases, the benefit remains the same and the premium increases with your age. In other cases, the benefit declines over time but the premium stays the same.

Whole life — also called **cash value** or **permanent insurance** — provides saving and investment options as well as a death benefit when you die. Premiums for these policies are higher than term policies for the same amount of coverage because part of the premium is used to build the cash value or savings.

Many companies offer limited or restricted life insurance policies. **Mortgage credit life** is an example of such a policy that your lender may offer. This insurance is not required and would only pay off your mortgage payment upon your death. This should not be confused with mortgage insurance described above.

Accidental death policies are another example of restricted life insurance. Generally, it is cheaper and wiser to purchase life insurance with broader coverage. Talk to your insurance agent regarding the best coverage for you.

Auto insurance

As with homeowner's insurance, if you have a loan on your vehicle, the lender will require you to have insurance and to list the lender as a loss payee on your policy.

Your auto insurance package

When you purchase auto insurance, you will be offered a variety of different coverages, each with its own premium. Basic coverages include the following.

Liability insurance covers injury and property damage to others if you or your vehicle causes an accident. This covers medical bills, lost wages, pain and suffering claims as well as repair or replacement of damaged property.

Many states require liability insurance coverage. Even if insurance is not required, you will want to have it to protect your home from being seized to pay for damages.

Collision coverage covers repair or replacement of your vehicle when damage results from a collision with another vehicle or object or a rollover.

Comprehensive covers damage to your vehicle from other causes, such as theft, storm damage, falling objects, fire or vandalism.

How to obtain insurance — Homeowner's, auto, life

Ask your neighbors, co-workers or friends for suggestions. Ask if they have had experience with making claims. Were they pleased with the service, and did the claim increase their premium?

Insurance agents

You may choose to work with an insurance agent who will serve as your contact with your insurance carrier. This person may be a **direct writer** who is an agent of a particular insurance company, or an **independent agent** who represents

several companies. In either case, your agent can offer you several types of insurance including homeowner's, auto and life insurance.

There may be discounts for having more than one type of insurance with a company. Your agent can review your family's insurance needs and help you select the policies that best meet your needs.

Direct sales

You can purchase insurance by phone, through mail offers or on the Internet. In these cases, you are not likely to have contact with a specific insurance company representative. Your claims would be handled in the same way as you purchased coverage — by phone or Internet.

Direct sale insurance options are promoted as being less expensive because of centralized processing.

Review your health and disability coverage.

Generally, you will obtain health and disability insurance benefits from your employer. Now that you are a homeowner, covering income lost because of medical problems becomes more important.

Your home is a financial asset, and creditors such as those collecting for medical bills may take an interest in your property.

Review your health and disability insurance coverage as a family. Are all family members protected? Do you know how and when disability coverage becomes

available? Do you have enough savings to pay your obligations for the months before the policy would start paying benefits? See the fact sheet *Emergency fund* in this manual.

Resources

Insurance Information Institute
www.iii.org

Insurance Institute for Highway Safety,
Highway Loss Data Institute
www.carsafety.org

Insure.com — Independent news
organization that does not sell
insurance, owned by Insurance News
Network
www.insure.com

Life Insurance Buying Guide
National Association of Insurance
Commissioners
www.naic.com

National Flood Insurance Program
(800) 611-6123
www.fema.gov/nfip

National Insurance Consumer Helpline
(800) 942-4242

Wisconsin Office of the Commissioner of
Insurance
(800) 236-8517
[badger.state.wi.us/agencies/oci/
oci_home.htm](http://badger.state.wi.us/agencies/oci/oci_home.htm)

If you do not have a computer, try your local library. Most libraries have a computer connected with the Internet.

References

"Buying a Home and Your Insurance Needs," Wisconsin Office of the Commissioner of Insurance:
oci.wi.gov/pub_list/pi-100.htm

"Private MI Uncloaked: How It Really Works," Peter Miller, *MICA News*, March 14, 2000:
www.micanews.com/issues/media_clips

"Homebuyer Hints: How Mortgage Insurance Works," January 2000: www.mgic.com/hints.html

"Life Insurance Basics": www.insure.com/life/basics.html

"Auto Insurance Basics": www.insure.com/auto/basics.html

Home Wise

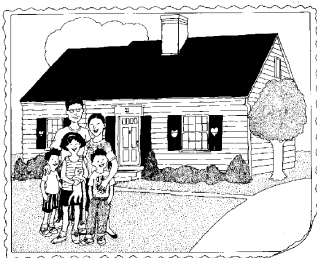

How much of your home do you own?

Home equity

What is home equity?

If you were to sell your home today, how much of the sale price would go into your pocket? This fact sheet is intended to help you figure this out.

The difference between the amount you can sell your home for and the balance of your mortgage is your **equity**. When you bought your home, your only equity was your down payment. Over the years, your equity increases in three ways:

- 1. Loan repayment** — Part of your monthly mortgage payments increases your equity. Each year, you receive a statement from your mortgage lender telling how much of your loan has been repaid. For the first several years of ownership, most of your payment goes for interest.
- 2. Improvements** — Adding a garage, remodeling the kitchen, or making other improvements can increase the value of your home, and thereby add to your equity. This increase is not based on what you paid for the work, but on how much more someone would pay for the house because the work was done. For example, adding a garage might cost \$5,000. But having the garage might only increase the price you could get for the house by \$3,500. A real estate agent may be willing to do a competitive market analysis of your home to determine the current **market value** or what you could sell your home for now including improvements.

- 3. Appreciation** — The value of your home can also increase as demand to buy houses increases, and with inflation. This type of increase is referred to as **appreciation**. Appreciation rates are different, depending on the neighborhood. They also change from year to year. Your annual property tax bill will contain an assessed value. The amount of increase in this figure from year to year gives you an idea of appreciation. The appreciation in the value of your home will be included in the “competitive market analysis” referred to in the previous paragraph.

What does this mean for an \$80,000 and a \$60,000 home after 5 years?

Example 1 — \$80,000 home

Tom and Linda paid \$80,000 for their home. They made a 3 percent down payment from their own funds. They also got help making the down payment from the city, in the form of a deferred loan for 2 percent of the purchase price. The 2 percent loan is due without interest when they sell the home. This loan provided the rest of the down payment. Their mortgage is for 30 years, at 8 percent interest.

The money Tom and Linda paid for closing costs does not increase their equity. After they bought the house, they added a garage at a cost of \$5,000. This increased the value of the home by \$3,500. House prices in their neighborhood have been going up about 4 percent a year. The following chart shows what their equity will be five years after they bought their house.

Example 1 — continued

Home equity after 5 years — \$80,000 home

Cash down payment	\$2,400
Principal repayment	\$3,747
Appreciation (4% per year x 5)	\$17,600
Improvements — Garage	<u>+ \$3,500</u>
Equity	\$27,247

The **equity** — \$27,247 — is how much of their home Tom and Linda will own. In 5 years, they will own nearly 28 percent of their home, which will then have a **market value** of about \$101,100. So if they sell then, they would receive about \$27,000. They would have to repay the 2 percent down payment loan to the city, and in many cases, a commission to a real estate agent.

Also, their lender would base a home equity loan on this amount. For example, their lender may estimate they could borrow 60 to 80 percent of the cash value of their home (equity) — \$16,350 to \$21,800. See *Home equity: Home equity loans fact sheet*.

\$80,000 home with improvements, 5 years from now

Market value	\$101,100
Amount the mortgage lender owns	\$72,253
Amount the city receives when they sell their house	\$1,600
Equity—cash value	\$27,247

In 5 years, Tom and Linda will own more than one-fourth of their home.

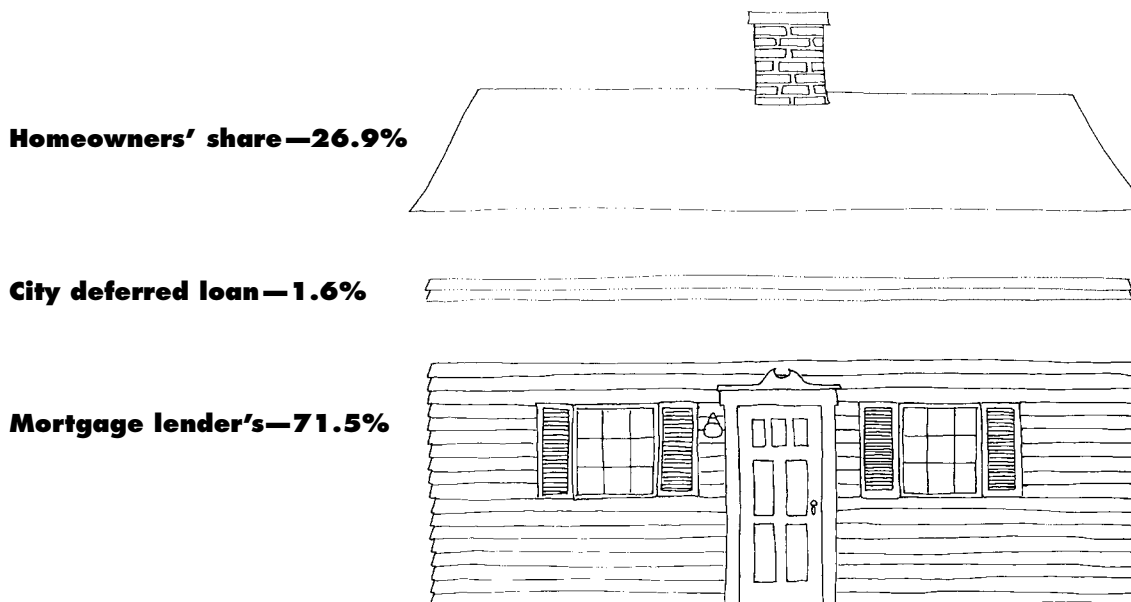

Example 2— \$60,000 home

Rose paid \$60,000 for her home. She received down payment assistance from her mother of a \$1,200 loan. She added this loan to \$1,800 from her savings to pay the 5 percent down payment. Her \$57,000 mortgage is for 30 years, at 8 percent interest.

Assuming Rose makes \$3,500 in improvements, the chart below shows what her equity will be 5 years after she bought her house.

Home equity after 5 years — \$60,000 home

Cash down payment	\$1,800
Principal repayment	\$2,810
Appreciation (4% per year x 5)	\$13,200
Improvements	+ \$3,500
Equity	\$21,310

In five years, Rose will own nearly 28 percent of her home — \$21,310 — which will then have a market value of about \$76,700. So if she sells then, she would receive about \$21,800. She would have to repay the down payment loan to the city, and in many cases, a commission to a real estate agent.

\$60,000 home with improvements, 5 years from now

Market value	\$76,700
Amount the mortgage lender owns	\$54,190
Amount Rose owes her mother	\$1,200
Equity—cash value	\$21,310

In 5 years, Rose will own more than one-fourth of her home.



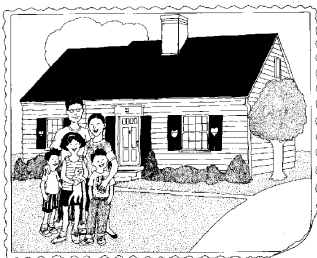

Home equity loans

What is a home equity loan?

As a homeowner, you have equity in your home. Lenders offer homeowners a special type of loan called a **home equity loan** or **line of credit**.

Your **equity** is the difference between the current value of your home and how much you owe on your mortgage. See *Home equity: How much of your home do you own?*

Equity includes:

- The down payment you made on your home.
- The part of your mortgage you have repaid.
- The increase in the value of your home since you purchased it. This increase is called **appreciation**, and varies from house to house.

Home equity loans offer cash at a lower interest rate than most other types of loans. You may be able to deduct the interest you pay from your income taxes.

Home equity loans are often in the form of a line of credit. This means you apply once, and then borrow against the loan over time. You can often spend from this line of credit through checks or a credit card. To get the loan, you pledge your home as **collateral** — security for the loan. Using your home as collateral means you risk losing it if you cannot make your payments.

While initial interest rates may be low, rates are often adjustable, and may rise over time. In some cases, you can make “interest only” payments. When this happens, your unpaid balance can grow — even though you are not using the line of credit.

In addition to the interest payments, you may need to pay a number of fees at the beginning to get the home equity loan. Many lenders periodically offer special promotions for home equity loans or lines of credit with no closing costs. Ask your lender about these offers.

Typical closing costs include fees for credit report, appraisal, title search, and loan commitment fee. Costs for these items are comparable to those charged when you purchased your home. There also may be an annual fee, and fees each time you use the loan.

Before you apply for a home equity loan, see if you can answer **yes** to the questions on the next page.



Check ✓

1. Is my income secure, so I won't have to worry about having enough money to make the payment? **Yes** **No**
2. Do I usually pay off loans quickly? **Yes** **No**
3. Not counting my mortgage payments, are all my loan payments less than 20 percent of my take-home pay? **Yes** **No**

Include loans to pay for a car, furniture, medical bills or credit cards as well as the home equity loan.

If any answers above are no, do not take on more debt. But if you answered yes to the first three questions, then consider these:

4. Does my mortgage have an adjustable interest rate? **Yes** **No**

If interest rates go up, your mortgage payments could rise at the same time as the interest rate on your variable rate home equity loan. Would this cause you problems making payments?

5. Is the loan for something I really need? **Yes** **No**

Would the loan be for large items for which you would need a loan even if you didn't use a home equity loan? Examples would be a major house repair or college tuition. A home equity loan in the form of a line of credit may tempt you to use the money for everyday expenses, such as clothes. In the long run, the interest you pay can make those clothes very expensive. Don't risk losing your home.

6. Would I be better off with a traditional second mortgage? **Yes** **No**

A second mortgage provides a fixed amount of money repaid with equal payments for a definite period of time. It is also secured by your home, and may have a relatively low interest rate. But since you get all the money at one time — not as a line of credit — you won't be tempted to spend it on ordinary purchases and extend the repayment period.

If you have considered these questions and decide to go ahead and get a home equity loan, compare several lenders before applying. The Home equity loan worksheet on the next page will help you compare lenders.

Home equity loan worksheet

	Lender A	Lender B	Lender C
1. Conditions of the loan			
How large a credit line?	\$ _____	\$ _____	\$ _____
Minimum initial withdrawal amount? How much?	\$ _____	\$ _____	\$ _____
Minimum or maximum withdrawal amounts after account is opened? How much?	\$ _____	\$ _____	\$ _____
Do I access this loan with checks or credit cards?	_____	_____	_____
How long to repay the loan?	_____	_____	_____
What is the maximum/	\$ _____	\$ _____	\$ _____
minimum monthly payment?	\$ _____	\$ _____	\$ _____

2. Interest rate

For **fixed** interest rate home equity credit lines:

What is the annual percentage rate (APR)? * _____% _____% _____%

For **variable** interest rates home equity credit lines:

What is the annual percentage rate (APR)? _____% _____% _____%

How often can the interest rate change? _____

Is there an interest rate cap? _____

Can the loan be converted to **fixed** rate? _____

* **Annual percentage rate** — This is the annual interest rate for a loan. The APR includes some standard charges, and how lenders must report this is consistent across all lenders. The APR is what to compare, and pick the lowest one.

3. Closing costs

Is the lender offering any promotional rates or terms? \$ _____ \$ _____ \$ _____

How many points? How much will the points be? \$ _____ \$ _____ \$ _____

How much is the application fee? \$ _____ \$ _____ \$ _____

How much is a title search? \$ _____ \$ _____ \$ _____

How much is the appraisal? \$ _____ \$ _____ \$ _____

How much are attorney's fees? \$ _____ \$ _____ \$ _____

Any other closing costs?
Explain: (list costs) \$ _____ \$ _____ \$ _____

Subtotal \$ _____ \$ _____ \$ _____

Which costs will the lender pay?
Subtract amount from subtotal. - _____ - _____ - _____

Total closing costs \$ _____ \$ _____ \$ _____

Home equity loan worksheet, continued

	Lender A	Lender B	Lender C
4. Continuing costs			
How much is the annual fee?	\$ _____	\$ _____	\$ _____
How much is each transaction fee?	\$ _____	\$ _____	\$ _____
5. Loan repayment			
How much is the fixed monthly payment, if any?	\$ _____	\$ _____	\$ _____
If a varying payment, how is it determined?			
A.	_____		
B.	_____		
C.	_____		
Does payment include principal and interest?	_____	_____	_____
What is the late payment penalty?	\$ _____	\$ _____	\$ _____
What are the conditions for default of the loan?			
A.	_____		
B.	_____		
C.	_____		
Can terms be changed without your consent?	_____	_____	_____
Is there a final balloon payment?	_____	_____	_____
Can the loan term be extended?	_____	_____	_____

Adapted with permission from:

A Consumer Guide to Home Equity Loans North Central Regional Extension Publication 384, by Sharon Burgess Seiling (Columbus, Ohio: Ohio State University Cooperative Extension), 1989.

Home Equity Credit Lines, Federal Trade Commission, June 1992.

Prepared by Rosalie Powell, professor and family resource management agent, Milwaukee County UW-Extension; and John Merrill, extension housing specialist, UW-Madison; and Kim Terry, housing and financial management educator, Milwaukee County UW-Extension with help from Dawn Davis, M&I Bank.

Home Wise

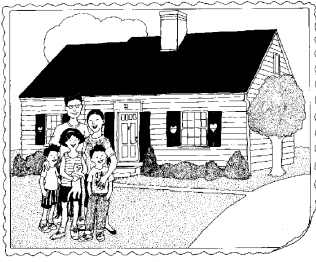

Refinancing your loan?

Home equity

As a homeowner, you are likely to be swamped with offers to refinance your home. The offers will suggest that you can get a lower interest rate, smaller payments and possibly more money so you have cash for a new car or other expenses.

How do you decide if refinancing is right for you?

Why refinance?

There are two major reasons to refinance:

1. Improve the terms of your mortgage.

- ✓ **Lower interest rate** — If interest rates are lower now than when you purchased, you may be able to reduce your monthly loan payments.
- ✓ **Shorter term** — If your income has increased or interest rates fallen, you may want to get a shorter term mortgage so you can pay the loan off more quickly and reduce interest charges.
- ✓ **Convert an adjustable rate loan to a fixed rate loan** — If you have an adjustable rate mortgage and interest rates on fixed rate loans are now attractive, you could refinance to get a stable interest rate. Some adjustable rate loans offer a conversion feature that can be cheaper and easier than starting with a new loan.

2. Obtain cash for other purposes.

Refinancing is one way to use the equity you have in your home to obtain cash for home improvements or other purposes. This is sometimes referred to as **cash out** refinancing. You could also get a home equity loan or second mortgage.

The advantage of refinancing, to get needed cash, is that you will still have only one payment to make, and you may get more favorable interest rates.

Conventional loans allow you to **borrow** at least 75 percent of the current value of your home. This will leave you with 25 percent equity or ownership. If you had to move or could no longer afford to make your payments, you would be able to sell your property.

Beware!

There are lenders that do not have the same limitations on how much you can borrow against your loan. Some will offer to lend you 100 percent or **more** of the value of your home.

This is dangerous because just as your home can increase in value, it can decrease in value as well. If you borrow more than your home is worth, you may not be able to sell the property later.

What does it cost to refinance?

Refinancing your home is similar to the process of acquiring your original mortgage. You will need to complete an application, the lender will obtain a credit report, appraisal, and update your title insurance policy.

Closing costs will also be similar. However, if you have enough equity in your home, you will be allowed to finance these costs into your new loan. This means that your loan amount will increase somewhat, and you lose some of the equity you have accumulated.

To save on closing costs:

- Talk to your current lender to see if the process can be completed more quickly or cost less because they hold your current mortgage.
- Keep the same type of loan — conventional, Federal Home Administration (FHA) or Veterans Administration (VA). This may reduce both time and closing costs.
- Look for special promotional offers with reduced closing costs.
- Make sure you get a Good Faith Estimate from your lender that details all your costs.

Other financing

You may have received down payment or rehabilitation assistance when you purchased your home. Many of these programs require no payments, or very low interest rate repayments. Often the balance owed declines over a period of time, such as the first 3 to 5 years, after which you owe nothing.

However, the agency providing the assistance probably filed a **lien interest** in your home so they will be repaid if you resell the property during this period.

If you have used a program that now has a lien on your home, you will need to evaluate the total cost of refinancing:

- ✓ Will you be required to pay off the balance? What will this do to your monthly payment? How will it impact your equity position?
- ✓ Will the assistance program subordinate their position? To subordinate means to allow:
 - the first mortgage to have a priority interest in your property, and
 - the assistance program to have a secondary position.

A subordination form signed by the assistance program must be filed with the county Register of Deeds for this to happen.

Many programs will not subordinate. Before moving forward with your refinancing plans, ask the agency that provided the assistance about their policy.

Weighing your options

Rate and term reduction

Compare what you will be saving in your monthly payment with how much it costs to refinance the loan. Evaluate the impact on your equity position.

Here is an example. You have a \$50,000 loan on your home, valued at \$60,000 when you bought it. The loan was at 8.5 percent interest for 30 years. Rates have dropped to 7 percent, and you would like to reduce your monthly mortgage payments.

In many cases, homes appreciate in value each year, so your home would likely be worth more in 5 years. To keep this example simple, assume that the value of the home did not change.

There will be closing costs to process your loan. You can estimate closing costs will equal about 2 percent of your loan amount. If you have enough equity, you can finance these as part of your loan. For this example, we have estimated closing costs at \$950.

Other considerations:

- ✓ Is the value of your home likely to increase?
- ✓ Are there tax advantages with refinancing rather than using a consumer loan?

	Value	Balance	Monthly payment²	Term remaining
Current	60,000	48,200	422.90	25 years
Refinanced	60,000	49,200 ¹	327.33	30 years
Difference	=	+1,000	-95.57	+5 years

¹Balance and closing costs rounded to nearest dollar.

²Monthly payment equals principal and interest only.

If you divide your closing costs by the amount you save each month, you can figure how many months until you recover the closing costs and start seeing your savings. In this case, when you divide \$1,000 by \$95.57, you see it would take a little more than 10 months of savings to offset the closing costs. Remember, if you make these payments for the full term of the loan, it will take 5 years longer to pay off the loan.

If you are considering refinancing as a source of cash, you can use much of the process described above. However, you also need to look at the other options for getting the cash you need. Compare the various costs of obtaining cash by refinancing to another option such as a home equity loan.

Reference: *Is Now a Good Time to Refinance?* By Fannie Mae, 1999. Fannie Mae Consumer Resource Center: (800) 732-6643 or www.fanniemae.com

Home Wise

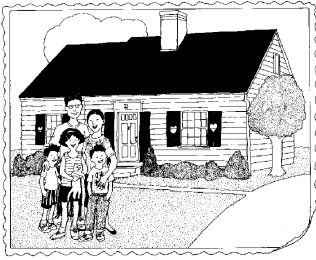

Protect your home equity

Home equity

Your equity in your home is a major asset. For most homeowners, this is the major source of wealth. As your equity grows, you will receive calls and advertisements encouraging you to borrow against that equity — without regard for your overall financial position.

You will want to protect the equity you have acquired. **So borrow:**

- **when you will use the money to increase the value of your home, and**
- **at loan terms you know you can afford.**

No credit/bad credit offers — Too good to be true?

Most mortgage lenders are reputable. However, some use high-pressure or deceptive practices to encourage you to borrow without regard for how difficult it may be for you to pay them back.

These lenders may be looking at the equity in your home as the way they will be repaid. Or they may collect enough in fees and interest at the beginning of the loan to make the risk worthwhile even if you default later.

Why would you or anyone choose to borrow money on these terms? These lenders specialize in making the process easy and hassle-free. This may be a tempting alternative — especially if you have been turned down by conventional lenders or are uncomfortable with the lending process.

What to watch out for

- A home improvement contractor offers to do work on your home and to arrange the financing to do it.
 - First, compare the bids of several contractors — especially if the contractor solicits the work by phone or at your door (see the fact sheet *Hiring a contractor*).
 - Second, the contractor and lender may have a financial arrangement that inflates your costs — or worse.
- You are asked to falsify your application in any way. Providing false information could jeopardize any legal remedy you may have if you are dissatisfied.
- The lender pressures you to borrow much more money than you had planned and dismisses your concern about being able to afford the monthly payments.
- Once you have a loan, the lender encourages you to refinance often, borrowing more money each time and incurring fees for each refinance. This is called **loan flipping** and the lender is seeking to earn the upfront fees as well as the added interest.
- The lender does not provide — or discourages you from reading — the required disclosures for such things as the cost of financing or your right to cancel. You may be asked to sign blank forms to be filled in later. The lender may say you cannot have copies of the forms you signed.

- You are offered one set of loan terms when you apply, but different terms when it comes time to sign the final documents.
- Your lender tells you or gives you the impression that voluntary credit life or disability insurance is required for the loan. Financing these costs increases the amount you need to pay back. You have the right to decline this insurance and:
 - shop around for the best insurance terms, or
 - protect yourself under a separate or existing life or disability policy.

What to do

Get a second opinion. If you are at all uncomfortable with how a lender is handling your loan request, seek advice before signing anything. Talk to an attorney, your housing counselor, or fair housing or lending organization.

Shop around. Talk to several local lenders about your loan needs. Compare terms, process and qualifying guidelines (use the *Home equity loan worksheet* in this manual).

If you find you cannot get attractive terms from conventional lenders because of credit problems or financial difficulties, talk to your local government or non-profit housing agencies. Many communities have home improvement loans available for homeowners at reduced or no interest and have more flexible credit standards.

Use your right to cancel. With loans that use your home as collateral, you have a 3-day right to cancel the transaction.

This **right of rescission** applies to:

- home equity loans,
- home equity lines of credit, or
- refinances where you are borrowing more than your outstanding mortgage balance.

If a homeowner has equity and wants to “cash out,” that would be subject to the 3-day right of rescission — for example, if you owe \$50,000 on a property valued at \$100,000 and want to refinance and borrow \$75,000.

You will be asked to sign a disclosure at closing advising you of this right, what you need to do to cancel, and when the 3-day period expires.

When you read over your loan documents and find you cannot live with the terms, you can exercise your right to cancel within the required time period.

Resources

AARP provides information and resources for avoiding predatory lenders. Call toll-free (800) 424-3410, or visit their Web site:

www.aarp.org/getans/predatorylending.html

Federal Trade Commission — For consumer protection and publications, call toll-free (877) FTC-HELP, or visit their Web site: www.ftc.gov

If you do not have a computer, try your local library. Most libraries have a computer connected with the Internet.

References:

“Avoiding Home Equity Scams,” Federal Trade Commission, September 1998.

Federal Reserve Bank of Chicago, Predatory Lending presentation, Felicia Kline, November 2000

“Think Twice About Using Your Home as Collateral,” Federal Trade Commission in cooperation with AARP, November 2000: www.aarp.org

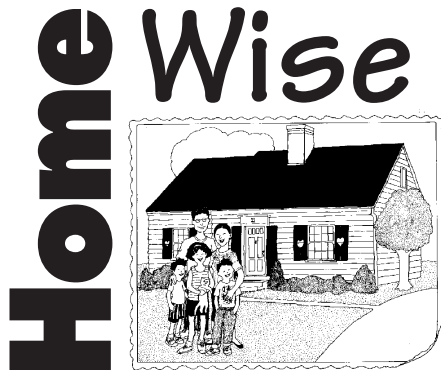

Income taxes and homeowners

What expenses can homeowners deduct?

Own^Oning a home can provide you with a break on your income taxes. Here is how this works for your federal income taxes.

The Internal Revenue Service (IRS) allows taxpayers to deduct certain expenses from their income before figuring the taxes they owe. These include:

- Interest on a home
- Property taxes on a home
- A portion of uninsured medical and dental expenses
- State or local income taxes
- Uninsured casualty and theft losses
- Contributions to charities
- Some business expenses

Many taxpayers do not figure the actual amount of their expenses. They simply use a "standard deduction" amount the IRS provides. There are two special large deductible expenses just for homeowners:

1. Interest paid on a home loan
2. Property taxes paid on a home

These two expenses alone often total more than the standard deduction, and is why homeowners often choose to use Schedule A and itemize their deductions.

Example

Sue is a single mother. In 2001, her standard deduction as head of household would be \$6,650, regardless of number of children.

If Sue paid interest all year on a \$70,000 mortgage with an 8 percent interest rate and a repayment period of 30 years, her payments for that year would be \$6,165. Since she has only owned the home for a year, almost all of her payments (\$6,000) is for interest. **Interest payment** will be the largest portion of her mortgage payment for many years.

Sue also paid \$2,500 in property taxes on her home. Adding this to her interest paid, by itemizing her deductions she could reduce her taxable income by \$8,500.

By itemizing, Sue's taxable income would be \$2,050 less than if she used the standard deduction. She may also deduct expenses such as money she gave to a church, temple or other charitable group. She can add other deductions to the \$8,500 and further decrease her taxable income — and pay less in taxes.

Note: This example is based on 2001 tax year IRS information.

What do you need to itemize deductions?

If you choose to itemize deductions, you will have to use the long income tax form, Form 1040 – U.S. Individual Income Tax Return and a Schedule A — Itemized Deductions. The IRS will provide an instruction book for completing Schedule A. In most cases, you must keep receipts for items listed.

You are not required to send in receipts for items you deduct. You are required to keep receipts, should the IRS want more information. You need to keep these records for 3 years:

- **Property taxes** — At the end of the year, you will receive a property tax bill from the city or county. Once these taxes are paid, keep the receipt.
- **Mortgage interest** — Early in the year, your mortgage lender will send you a form showing how much interest you paid in the last year. You probably pay money into an escrow account each month for property taxes. If so, the form you receive from the lender will also show how much you paid for property taxes.

Tax laws change from year to year, and can affect what you may deduct. Consult the person who completes your tax forms, or the Internal Revenue Service:

IRS toll-free hotline

(800) 829-1040

(800) 829-4059 (TTY)

Recorded tax help

(800) 829-4477 — 24 hours

IRS Forms and Publications

(800) 829-3676 — Allow 2 weeks.

Fax: (703) 368-9694

Or select Forms and Publications at the IRS Web site:

www.irs.gov

One-on-one tax help — VITA (Volunteer Income Tax Assistance) is available at many local libraries and other locations from January to April 15. Details are available from the IRS hotline or contact the Tax Education Unit of the IRS for your area.

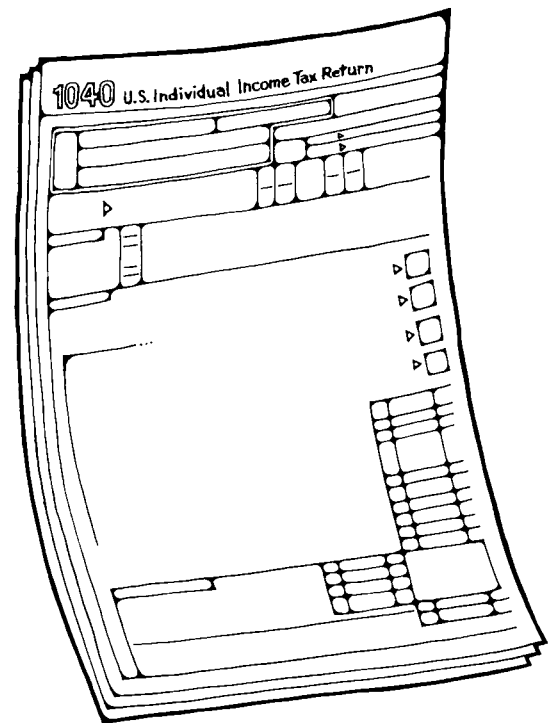

Home Wise

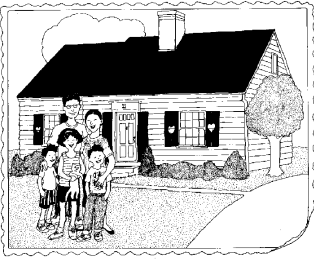

Property taxes

What is property tax?

Property tax is a tax on the value of real estate. This tax is a major source of money for local government. When your home was built, it was given a value for tax purposes. This value is known as the **assessed value**.

Local government officials figure how much money needs to be raised from property taxes. They then divide this amount by the total assessed value of all taxable property. This is the tax rate, sometimes stated as a decimal, e.g. .03048565 or dollars per \$1,000 of assessed valuation. See *Taxes: Sample property tax bill*.

How are property tax assessments determined?

Local state-certified tax assessors assess the value of your home. They base the property assessment on the amount for which you could sell the property.

- **For a new home** — The assessor will visit the home, and do a complete appraisal, comparing the home to other similar homes recently sold. The assessed value will be set in relation to the sale prices of these other homes.
- **For existing homes** — Assessments are reviewed each year, and may be raised to reflect overall increases in the value of similar homes.

How do repairs and improvements affect the assessed value?

Normal repairs and maintenance should not increase your assessment. This means that even though the job may be costly, replacing a water heater or painting the house should not increase your home's assessed value.

On the other hand, **improvements** that increase the **market value** of the house will increase the assessed value. If you add a deck or a garage, or remodel the kitchen, buyers will probably pay more for the house. The assessor will figure this increased value into your assessment.

How do you find your home's assessed value?

Your annual property tax bill will list the current assessed value. This bill also includes a breakdown of the value of your lot, referred to as "land," and buildings on the lot, referred to as "improvements." See *Taxes: Sample property tax bill*.

If your assessment increases, you will receive a notice of this change. This usually happens in the spring. You can also check with the city, village or town clerk or assessor. The clerk or assessor can show you the values of other properties as well.

What if you disagree with the assessment?

When you are notified of a property tax assessment increase, you also should be notified about the appeal process:

- First, review your records with the local assessor. The assessor can explain the basis of the increase.
- You can request a review of your assessment at any time. In this case, an assessor will come to your home for an inspection. Since most changes in assessment result from a market analysis and not inspections, this will be more accurate. Be aware that if you have made improvements that increase the value of your home that your municipality is not aware of, this inspection could result in an increase in your assessment.
- If you disagree with your assessment, you can file an objection. A Board of Review makes the decision regarding your objection. This is now a two-step process:
 1. First, you must file an Intent to Object at least 48 hours before the Board of Review meets. If you can show good cause why you could not meet this deadline, the time frame is shortened to the beginning of the day the board meets.
 2. You will file an objection and present your case in person to the Board of Review.

File your objections on time. Review with your tax assessor's office how the process works in your community. The Board of Review has no obligation to review your objection if you do not follow the process.

How do you pay property taxes?

Property tax bills are usually mailed to you as the homeowner in December. For many homeowners, part of their monthly mortgage payment goes into an escrow account to cover their annual property taxes. Those without an escrow account will make their payments directly to the city, village or town treasurer's office.

If you have an escrow account:

When you close on your loan, you will be given three options on how you would like your property taxes paid:

1. By December 20, you will be sent a check made payable to you and the municipality for the amount collected for property taxes. You will be responsible for making the property tax payment.

With this method, you control when the taxes are paid. If you want to claim the property tax payment on the current year's tax return, you will need to make payment before December 31. If your mortgage loan servicer collected less than was due, it is your responsibility to make up the difference. If more money was collected than is due, you can keep the difference. You are responsible for sending a paid receipt to your loan servicer by March 31.
2. You can request that your loan servicer pay the taxes prior to December 31. You must make sure they receive a tax bill by December 20. You will need to get a receipt of payment for your income tax records.
3. You can request that your loan servicer pay your taxes when due. If paid in full, taxes must be paid by January 31. This is typically how a loan servicer would pay them.

Taxes

Sample property tax bill

This is a generic property tax bill, supplied by the Wisconsin Department of Revenue.

<p>Local gov. collects for each of these taxing jurisdictions</p> <p>Local gov. assessed value of land</p> <p>Local gov. assessed value of buildings</p> <p>Local gov. assessed value of land and buildings</p> <p>Town's Total Assessed Value divided by State Equalized Value (as a %)</p> <p>A value estimate made by dividing this parcel's Total Assessed Value by the Average Assessment Ratio</p> <p>Delinquent taxes due on this property</p>		<p>Make check payable to:</p> <p>ELLEN JONES TREASURER, TOWN OF BADGER RR 9, P.O. BOX 6890 BADGER, WI 58425</p> <p>REAL ESTATE PROPERTY TAX BILL FOR 2001</p> <p>STATE OF WISCONSIN TOWN OF BADGER AMERICA CO.</p> <p>CARSON, DAVID Z BILL NO. 3009 Correspondence should refer to tax number. See reverse side for important information. PARCEL # 12-116-0029-0000</p>		<p>Assessed Value: LAND 22,000</p> <p>Assessed Value: IMPROVEMENTS 67,000</p> <p>TOTAL ASSESSED VALUE 89,000</p> <p>Avg. Assmt. Ratio 93.15%</p> <p>EST. FAIR MKT. LAND 23,600</p> <p>EST. FAIR MKT. IMPROVEMENTS 71,900</p> <p>TOTAL EST. FAIR MKT. 95,500</p> <p>NET PROPERTY TAX \$ 1,632.26</p> <p>SEWER MAIN 359.02</p> <p>SNOW REMOVAL 195.00</p> <p>TOTAL DUE FOR FULL PAYMENT PAY BY JANUARY 31, 2002 \$ 2,186.28</p>		<p>AVG. ASSESSMENT RATIO 93.15%</p> <p>EST. FAIR MKT. LAND 23,600</p> <p>EST. FAIR MKT. IMPROVEMENTS 71,900</p> <p>TOTAL EST. FAIR MKT. 95,500</p> <p>NET PROPERTY TAX \$ 1,632.26</p> <p>SEWER MAIN 359.02</p> <p>SNOW REMOVAL 195.00</p> <p>TOTAL DUE FOR FULL PAYMENT PAY BY JANUARY 31, 2002 \$ 2,186.28</p>	
<p>Amount from State to reduce each tax bill.</p> <p>Gross tax due for 2001 to each tax jurisdiction. For comparison, the taxes due for 2000 are listed with the percent change.</p> <p>Lottery Credit amount from the State for 2001</p> <p>Total Assessed Value multiplied by the Net Assessed Value Rate</p> <p>The rate for this tax bill before Lottery Credit</p> <p>Normal option allows for payment in full or two installments</p>		<p>TOTAL ASSESSED VALUE 89,000</p> <p>AVG. ASSESSMENT RATIO 93.15%</p> <p>EST. FAIR MKT. LAND 23,600</p> <p>EST. FAIR MKT. IMPROVEMENTS 71,900</p> <p>TOTAL EST. FAIR MKT. 95,500</p> <p>NET PROPERTY TAX \$ 1,632.26</p> <p>SEWER MAIN 359.02</p> <p>SNOW REMOVAL 195.00</p> <p>TOTAL DUE FOR FULL PAYMENT PAY BY JANUARY 31, 2002 \$ 2,186.28</p>		<p>EST. STATE PAYS TO TAX DIST. 2000 67,000</p> <p>EST. STATE PAYS TO TAX DIST. 2001 89,000</p> <p>NET TAX 2000 401.25</p> <p>NET TAX 2001 190.05</p> <p>% TAX CHANGE 3.8%</p> <p>3.0%</p> <p>-2.7%</p> <p>2.4%</p> <p>1.4%</p> <p>1.8%</p> <p>53.1%</p> <p>-1.2%</p> <p>Net Assessed Value Rate (Does NOT include Lottery Credit) 0199917</p> <p>Or Pay 1st Installment \$ 1,296.65 by JANUARY 31, 2002</p> <p>Or Pay 2nd Installment \$ 889.63 by MAY 31, 2002</p> <p>Warning: If not paid by due dates, installment option is lost and total tax is delinquent subject to interest and if applicable, penalty. (See reverse)</p> <p>Special Change Paid</p> <p>Special Assessment Paid</p> <p>Property Tax Paid</p> <p>Total Amount Paid</p> <p>Balance Due</p> <p>Paid by</p> <p>Rec'd by</p> <p>Date</p>		<p>TOTAL ASSESSED VALUE 89,000</p> <p>AVG. ASSESSMENT RATIO 93.15%</p> <p>EST. FAIR MKT. LAND 23,600</p> <p>EST. FAIR MKT. IMPROVEMENTS 71,900</p> <p>TOTAL EST. FAIR MKT. 95,500</p> <p>NET PROPERTY TAX \$ 1,632.26</p> <p>SEWER MAIN 359.02</p> <p>SNOW REMOVAL 195.00</p> <p>TOTAL DUE FOR FULL PAYMENT PAY BY JANUARY 31, 2002 \$ 2,186.28</p>	
<p>State of Wisconsin Taxing Jurisdiction</p> <p>STATE OF WISCONSIN AMERICA COUNTY TOWN OF BADGER BLOOMING SCHOOL DIST TECH. COLLEGE</p> <p>TOTALS 668,121</p> <p>School leaves reduced by school levy tax credit \$486.57</p> <p>IMPORTANT: Be sure this description covers your property. This description is for this tax bill only and may not be a full legal description.</p> <p>23/333 45/111 1/2 00A SEC. 31, T 1 N, R 22 E THE W 330' OF THE NE 1/4, NE 1/4 SEC. 31</p> <p>DAVID Z CARSON RR 9 ADDRESS BADGER, WI 58425</p>		<p>EST. STATE PAYS TO TAX DIST. 2000 67,000</p> <p>EST. STATE PAYS TO TAX DIST. 2001 89,000</p> <p>NET TAX 2000 401.25</p> <p>NET TAX 2001 190.05</p> <p>% TAX CHANGE 3.8%</p> <p>3.0%</p> <p>-2.7%</p> <p>2.4%</p> <p>1.4%</p> <p>1.8%</p> <p>53.1%</p> <p>-1.2%</p> <p>Net Assessed Value Rate (Does NOT include Lottery Credit) 0199917</p> <p>Or Pay 1st Installment \$ 1,296.65 by JANUARY 31, 2002</p> <p>Or Pay 2nd Installment \$ 889.63 by MAY 31, 2002</p> <p>Warning: If not paid by due dates, installment option is lost and total tax is delinquent subject to interest and if applicable, penalty. (See reverse)</p> <p>Special Change Paid</p> <p>Special Assessment Paid</p> <p>Property Tax Paid</p> <p>Total Amount Paid</p> <p>Balance Due</p> <p>Paid by</p> <p>Rec'd by</p> <p>Date</p>		<p>TOTAL ASSESSED VALUE 89,000</p> <p>AVG. ASSESSMENT RATIO 93.15%</p> <p>EST. FAIR MKT. LAND 23,600</p> <p>EST. FAIR MKT. IMPROVEMENTS 71,900</p> <p>TOTAL EST. FAIR MKT. 95,500</p> <p>NET PROPERTY TAX \$ 1,632.26</p> <p>SEWER MAIN 359.02</p> <p>SNOW REMOVAL 195.00</p> <p>TOTAL DUE FOR FULL PAYMENT PAY BY JANUARY 31, 2002 \$ 2,186.28</p>		<p>TOTAL ASSESSED VALUE 89,000</p> <p>AVG. ASSESSMENT RATIO 93.15%</p> <p>EST. FAIR MKT. LAND 23,600</p> <p>EST. FAIR MKT. IMPROVEMENTS 71,900</p> <p>TOTAL EST. FAIR MKT. 95,500</p> <p>NET PROPERTY TAX \$ 1,632.26</p> <p>SEWER MAIN 359.02</p> <p>SNOW REMOVAL 195.00</p> <p>TOTAL DUE FOR FULL PAYMENT PAY BY JANUARY 31, 2002 \$ 2,186.28</p>	

You can change the method of property tax payment. Notify your loan servicer by November 1. If you are not current on your mortgage payments, your lender may select the tax payment method.

If you do not have an escrow account:

If you do not have an escrow account with your lender, you will be responsible for payment of the property taxes. Set up a savings account similar to your lender's escrow account so you have the funds when the bill is due.

If you do not have payment in full by January 31, you have the option to pay on an installment plan:

- **Two payments** — The first payment is due January 31, and the second July 31.
- **Monthly payments** — The first is due January 31, and the final October 31.

You are not charged additional interest for paying with the installment plan.

What happens if you are late paying property taxes?

Beginning February 1, the day after the first installment is due, you will be charged interest on the full unpaid property tax. The interest rate is at least 1 percent per month (some counties charge an additional amount). One percent of \$2,000 is \$20.

Soon after the final installment is due, the county sends a notice to all property owners who still owe taxes. This informs them that if taxes are not paid within 2 years, they will lose title to their property through foreclosure.

Homestead Tax Credit — Help paying property taxes

The state of Wisconsin and many other states have a program known as the **Homestead Tax Credit** to ease the burden of property taxes on households with low or moderate incomes. This credit is available to renters as well as homeowners. The specifics of the program vary each year.

Income limits change yearly. The credit decreases as income increases within the range of qualifying income.

For more information about the Homestead Tax Credit, contact:

Wisconsin Department of Revenue
P.O. Box 8903
Madison, WI 53708
(608) 266-1961

See also *Taxes: Income Taxes and Homeowners*.

References:

M. Hennen, tax assessor, City of West Allis, Wisconsin.

Wisconsin Department of Financial Institutions, "Commonly Asked Questions on Escrow Accounts Established to Pay Real Property Taxes or Insurance or Both," 1998:
www.wdfi.org/yymm/tip_of_month/0298tip.htm

Home Wise

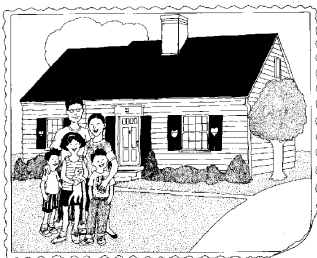

How long things last

Repair or replace

Planning ahead for replacements

Keeping your home as “brand new” as possible means you will have to replace parts of home systems as they wear out or break down. Planning ahead can help you know how much to save for replacement costs.

This table lists the average life of different things around the home. You can get an idea of the cost of replacing items in your home by checking with contractors, real estate professionals and home centers.

Remember that you may have to replace items with a short life expectancy several times. You can reduce these costs by doing some or all of the work yourself. See *Repair or replace: Should you do a repair yourself?*

When you have repairs made or buy a new appliance or other equipment, keep the receipts, owner’s manual and warranty. Also list these on a household inventory like the one provided on page 109.

Life expectancy*	Item**
5-10 years	Paint — exterior
	Paint — interior
10-20 years	Faucets
	Laminate countertops
	Water heater
	Central air conditioning
	Carpeting
	Wood deck
	Asphalt driveway
15-25 years	Oven or stove
	Furnace or boiler
	Vinyl floor
	Shingle roof
	Wood floors
25 + years	Gutters
	Siding
	Chimney
	Concrete driveway

* This is an average. Your items may have a longer or a shorter life.

** Based on “Life Expectancy of Housing Components” by Gopal Ahluwalia and Angela Shackford, *Housing Economics*, August 1993.

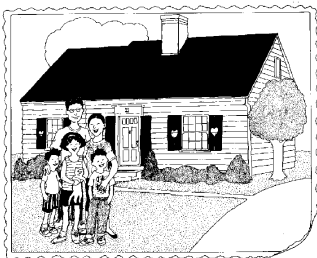

Should you do a repair yourself?

Why make repairs yourself?

Most homeowners do at least some of their own home repairs. This fact sheet will help you think first about whether you want to make your own repairs, and then which repairs you want to do yourself.

Think about the rewards for doing your own repairs:

- **Savings** — You can save money if you have what you need to do the job, and do it right.
- **Convenience** — Doing your own repairs can be more convenient than waiting for a contractor and scheduling the repair around his or her schedule.
- **Learning** — By doing your own repairs, you grow to understand the way things work in your home, and can often catch problems before they become disasters. You also develop the confidence and understanding to deal more effectively with contractors when you need a bigger job done.
- **Accomplishment** — You gain a sense of satisfaction in making something work.

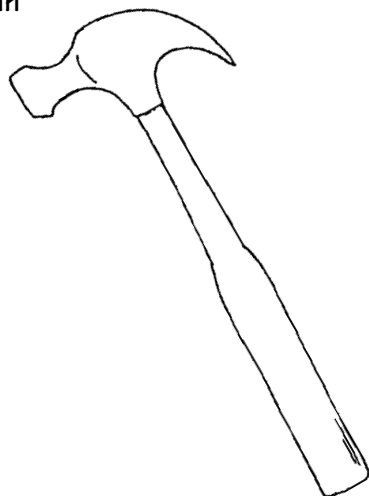

Are you right for the job?

Next, think about whether you have the ability and resources to do your own repairs:

- *Patience and confidence can be as important as skill. You can develop all three of these:*
 1. Before you start a project, learn about what you plan to do:
 - Read.
 - Attend classes.
 - Ask trades people, or friends who are do-it-yourselfers.
 2. Start with small jobs.
- Self-help books are available everywhere, with step-by-step instructions for a variety of repairs.
- Many new home repair products are intended for use by homeowners. They come with instructions and telephone numbers for extra help, and they don't require special skills.

Questions to ask yourself

? What are the costs of making mistakes?

In some cases, the consequences may be slight. For example, if a faucet still leaks, you are no worse off than when you started. On the other hand, you may expand the problem in the course of attempting to fix it, or you may ruin the replacement part.

? Does the job require an expert?

Some jobs require special skill and experience. See *Repair or replace: Hiring a contractor for major repairs or remodeling*. Reasons for hiring an expert:

- If you don't do the job right, you could create a safety hazard or make the original problem worse.
- If you're unable to finish the job, the result may inconvenience and stress other household members.
- If the finished job looks like a do-it-yourself job, it could prove a problem should you try to sell the home.

Sometimes you can save money by hiring a contractor and doing some of the work, such as sanding and staining for a carpenter.

If your house is new, check with the builder. The problem may be under warranty.

? Will you really save money?

Labor is the major cost for many jobs, so doing repairs yourself can cut costs by 50 percent or more. But there are other costs to consider:

- **Special tools** — When you count the cost of tools you buy for the job, is it still cheaper to do it yourself?
 - Will you use them again?
 - Can you rent them?
- **Excess material** — Will you have to buy materials in large quantities, so that you pay for materials you don't use?
- **Cost of mistakes** — When doing a job the first time, are you likely to mismeasure or damage materials so that you have to buy parts or supplies

twice?

- **Time** — Could you use the time more effectively to spend time with your family or to earn money?

? Do you have the time?

Figure that a new job will take you two to three times as long as you plan.

Making repairs during evenings and on weekends means that you spend much of your time setting up, cleaning up and figuring out where you left off.

These factors also add to the time a new job takes:

- Learning as you go
- Not having the professional equipment contractors use
- Correcting mistakes
- Buying added material that you didn't know you needed

? Is your family ready?

Family members may resent your lack of time for other activities. They may be frustrated by the mess, noise, disruption in routine and lack of access to parts of the house. Can your family accept and cope with this added stress?

? Should you do it yourself?

You must answer this question for yourself. This fact sheet is meant to help you select jobs that you can complete successfully and economically. If you decide you shouldn't do a job, see the fact sheets *Hiring a contractor for major repairs and remodeling* and *Hiring someone for minor repairs*.

Home Wise

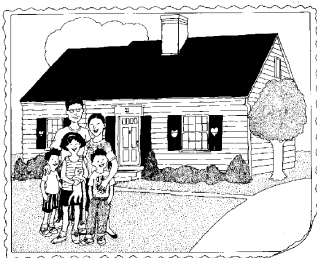

Hiring a contractor for major repairs or remodeling

Repair or replace

Who's the right person for the job?

As a homeowner, you may have to find a plumber, carpenter or other repair person to work on your house. While most repair workers are honest and fair, one of the most common causes of consumer complaints is "home repairs."

This fact sheet can help you select the right person for the job, and avoid problems. If your house is new, check first with the builder. The problem may be under warranty. If you are trying to decide whether to do a job yourself or hire someone, see *Repair or replace: Should you do a repair yourself?*

Locating potential contractors

Start by asking friends and neighbors for recommendations. Hardware stores, lumber yards, insurance agents and lending institutions may also be able to recommend contractors. If you do not know what type of contractor you need, see the list of contractors needed for common jobs at the end of this fact sheet.

For large jobs, get estimates from at least three potential contractors. This way, you can compare prices and get different opinions about how the work should be done.

Be especially cautious with contractors who come to your door or call you on the phone to offer services. While legitimate businesses use these techniques, this is often the way home repair fraud is initiated. You may receive inferior products or service — or nothing at all — for your money.

Questions to ask potential contractors

Before you begin calling contractors, decide exactly what you want done. Get information from your local library or lumber yard about the work you want done. This will help you understand the options you have, and the terms contractors use.

Write down a list of questions you want to ask each contractor you call. Use the same description of the work you want done with each contractor. Here are some things you need to know about potential contractors and the job you want done:

? Is the contractor really in business?

- Check whether the person has letterhead stationery, a brochure, business card and a telephone number.
- Ask if he or she belongs to any trade associations.
- For plumbers and electricians, ask to see their state license.
- Who will actually be doing the work? Will it be the person you talked with?

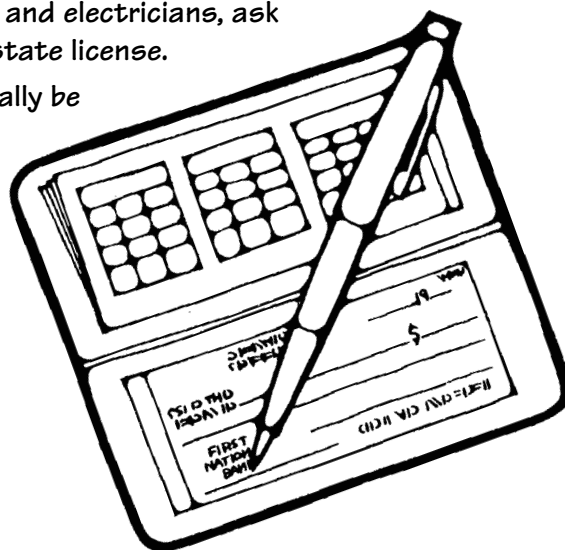

? *Is the contractor fully insured?*

Contractors should have liability insurance and workers' compensation insurance, or you may be liable for accidents on your property.

- Ask the contractor for proof of current insurance coverage.
- Write down the insurance agent's name and phone number, as well as policy numbers.

? *Does the contractor have a good reputation?*

- Ask where the contractor plans to purchase material, and contact the supplier to see if the contractor pays bills on time.
- Call the local building inspector, Better Business Bureau, Home Builders Association, Building Trades Council, consumer protection office or chamber of commerce to see if anyone has filed a complaint against the contractor.

? *Does the contractor have good references?*

Ask for names and phone numbers of previous customers. Call at least two of these. Here are some questions you might ask:

- How did you decide to use this contractor?
- What work was done for you?
- Did workers keep the work area neat and clean?
- Was the work completed at the price stated in the contract?
- Was the work completed on time?
- Are you happy with the finished product?
- Would you hire this contractor again?

Ask to see the work, and inspect the quality.

? *What building permits are required?*

The contractor should be able to tell you what building permits are required, and should agree to get them. Building permits add to your expenses, but the cost is worth it in assuring quality work.

? *How do estimates compare?*

Ask for a written estimate of what the work will cost. For many jobs, the estimate will be in the form of a contract you can sign if you want to hire the contractor. When comparing different contractors' estimates, be sure they all use the same materials and based their bids on the same work.

Construction contracts

While contracts may be written or oral, it is wise to obtain a written contract. Oral contracts cannot always be enforced. Written contracts are required by law whenever you are obligated to pay money before the job is completed.

Never sign a blank contract, or one with blank spaces. You are entitled to an exact copy of your contract at the time you sign it. If you don't understand parts of the contract, have someone go over it with you.

DO NOT pay the full amount contracted "up front." Arrange payments in stages as the work is finished.

What is a lien waiver?

For larger repair or remodeling jobs, contractors may hire other contractors to do some of the work. The contractor is responsible for paying these subcontractors.

A **lien waiver** is a kind of receipt the contractor should give you in exchange for your first payment on the contract. If the contractor fails to pay subcontractors, this lien waiver protects you from subcontractors seeking payment from you.

Canceling a contract

State and federal laws allow a 3-day cancellation period for contracts:

- Signed away from the contractor's office.
- In amounts of \$25 to \$25,000.

You must be informed of your cancellation rights orally and in writing, and two sets of forms for canceling must be provided for you to use. You have until midnight of the third business day to cancel a contract. Do this by registered mail, and keep one copy. You may also send a telegram.

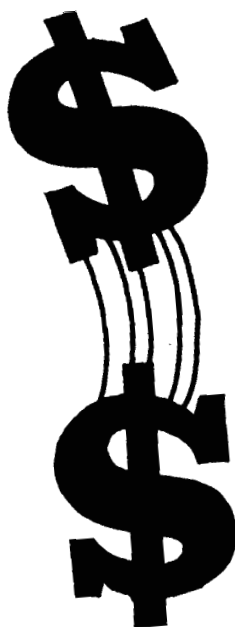

If problems arise...

- **Try to resolve problems with the contractor directly.** Do this in writing, with both of you receiving a copy.
- **Contact the contractor's trade association.** The association may act as an intermediary, or arrange arbitration to help you settle the problem with the contractor.
- **If you cannot resolve your problems, contact:**

Wisconsin Department of Agriculture,
Trade and Consumer Protection
(800) 422-7128 — Consumer Hotline
In Madison: 224-4960 or 224-4950
FAX: (608) 224-4939

Wisconsin has a "Home Improvement Trade Practices Code," ATCP 110. This is designed to protect homeowners from common abuses and fraudulent schemes. The code covers repairs and remodeling of existing structures, including carpet installation, heating and air conditioning, furnaces, water softeners, fire protection devices, garages, swimming pools, sidewalks, driveways, patios, porches and landscaping.

Any person suffering monetary loss as a result of a violation of ATCP 110 may sue and recover twice the amount of such loss together with court costs and reasonable attorney fees.

What type of contractor do you need?

Listed below are a number of common household problems, and who to call for professional help.

Repair or replace	Professional(s)	Other help
Brick or stone chimney	Mason	
Carpet or vinyl floor	Carpet layer	Businesses that sell flooring can recommend installers.
Concrete stoop, driveway or walk	Concrete contractor	
Doors	Carpenter	
Furnace, boiler or hot water heater	Heating contractor, fuel supplier, plumber, steam fitter	Contact your utility company for advice and possible financial help.
Holes in interior walls	Drywall contractor	
Insulation	Insulation contractor	Contact your utility company for advice and possible financial help.
Lock installation	Lock smith, carpenter	
Painting — interior or exterior	Painting contractor	Contact Health Department regarding contractors certified for lead abatement.
Light switches, outlets or wiring	Electrician	
Water pipes, drains or plumbing fixtures	Plumber	
Roof	Roofing contractor	
Wet basement	Waterproofing contractor	
Window glass		Hardware store, window supplier

Adapted with permission from:

“Consumer approval transactions and advertising,” Commissioner of Banking, *Wisconsin Statutes*, Chapter 423.

Home improvement and repairs, Office of Consumer Protection, Wisconsin Department of Justice, June 1982.

“Home improvement trade practices,” Agriculture, Trade & Consumer Protection, *Wisconsin Statutes*, Chapter ATCP 110.

“Liens,” Commissioner of Banking, *Wisconsin Statutes*, Chapter 779.

Reprinted with permission from the Council of Better Business Bureaus, Inc., from *Tips on...Home Improvement 205*, copyright © 1995, Council of Better Business Bureaus, Inc., 4200 Wilson Blvd., Arlington, VA 22203

Home Wise

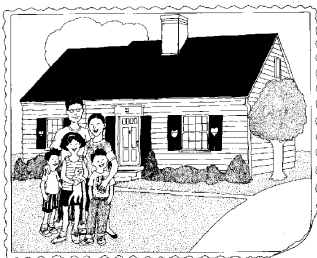

Hiring someone to help with minor repairs

Repair or replace

What if something needs fixing?

As a homeowner, you cannot call the landlord if the furnace doesn't come on or you have a plumbing leak or the garage door doesn't open.

You may choose to fix some things yourself. If you are considering this, see the fact sheet *Should you do a repair yourself?*

If you are going to hire a repair done, you will need to figure how you are going to pay for it, and know whom to call and what to expect. While most repair workers are honest and fair, one of the most common consumer complaints is home repairs.

Locating the help you need

Start by asking friends and neighbors for recommendations. Hardware stores, lumber yards, insurance agents and lending institutions may also be able to recommend repair people. For small repairs, usually getting a positive recommendation from someone you trust is enough on which to base your choice.

If you do not know what type of help you need, see the list of contractors for common jobs at the end of fact sheet *Hiring a contractor for major repairs or remodeling.*

Be especially cautious with contractors who come to your door or call you on the phone to offer services. While legitimate businesses use these techniques, this is often the way home repair fraud is initiated. You may receive inferior products or service — or nothing at all — for your money.

What to expect

Anyone you hire to come into your home and make a repair is a **contractor**. Even if there is no written contract, there is an understanding that the person will do the work in a workmanlike manner and you will pay for the time and materials.

When you contact the company to come and make the repair, say that you would like a written estimate before the work starts. Sometimes estimates are hard to make before work begins, because the extent of the work is unknown. If the company is reluctant to give a written estimate, they at least should be willing to give you a range of likely costs.

Repair companies differ on when they expect payment. Most larger companies will leave you an invoice when the work is completed. It describes the work done but may not include the cost. Later, you will receive a bill from the company with payment terms. Other companies will expect to be paid after the work is complete and before they leave your home.

Avoid paying cash for repairs. If you do, be certain you get a receipt. Your receipt and invoice or bill will be important if you discover a problem with the repairs.

If problems arise...

- **Try to resolve problems with the contractor directly.** Do this in writing, with both of you receiving a copy.
- **Contact the contractor's trade association.** The association may act as an intermediary, or arrange arbitration and help you settle the problem with the contractor.
- **Contact the Wisconsin Bureau of Consumer Protection.** Wisconsin has a "Home Improvement Trade Practices Code," ATCP 110. This is designed to protect homeowners from common abuses and fraudulent schemes. Routine repairs, carpet installation, heating and air conditioning, furnaces, water softeners, fire protection devices, garages, swimming pools, sidewalks, driveways, patios, porches, and landscaping are covered. Contact the bureau by calling: (800) 422-7128

Reference:

Agriculture, Trade & Consumer Protection. *Home improvement trade practices.* Wisconsin Statutes, Chapter ATCP 110.

Home Wise

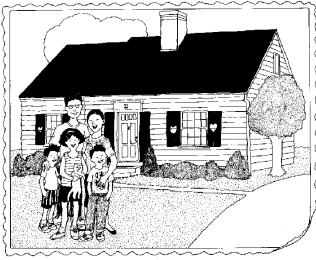

Homeowner records

John Merrill, Kim Terry and Rosalie Powell

Contents

Record keeping

What to keep, where to keep it . . . 107

Household purchase inventory . . . 109

Resources

Quick reference list 111

Homeowner resources 113

Add your own homeowner records and resources to this section.

Home Wise

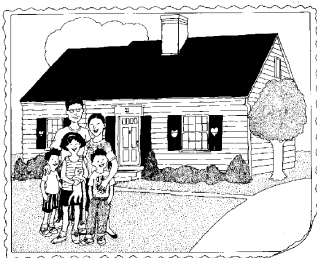

What to keep, where to keep it

Record keeping

Home purchase records

This fact sheet is to help you decide which documents about your house to keep, how long to keep them, and where.

While you are in the process of purchasing your home, you receive a number of important papers. These can include:

- Pre-purchase inspection report for your home
- Property survey
- Signed offer to purchase
- Mortgage
- Promissory note
- Title insurance commitment (final policy will be mailed to you)
- Settlement statement (describes how funds from the transaction were applied)
- Lien waivers for work done by seller in last 6 months
- Loan repayment schedule
- Copy of homeowner's insurance policy
- Appraiser's report — Ask your mortgage lender for a copy.

There are some other records you should keep because they will help answer questions about the house. The previous owner may leave you these records:

- Architect's drawings
- Warranties of building components such as windows, furnace, water softener, and use and care manuals
- Well and septic system records
- Receipts for work done

- Homeowner association requirements or neighborhood covenants

Why keep these records?

There are several reasons to keep these records:

- You may need to show how much you paid for the home, should you resell it.
- You may want to contact someone involved in the sale.
- You may want to review a document if there is some type of dispute.
- You may want to clean or adjust something, order a part, or get directions for a repair.

How long should you keep these records?

- Keep documents about the mortgage until the mortgage is completely repaid.
- Keep a record of how much you paid for the home until you sell it.
- Keep documents relating to building components or equipment until you replace or dispose of the component or equipment. If records are for expenses that increased the value of your home — such as an added bathroom — keep them at least until you sell the house.
- You will receive a final **title insurance policy** after you close on your loan and your deed and mortgage have been recorded with the county Register of Deeds. You will be asked for this each time you borrow against your home and when you sell your property. Each time you use your home as collateral, the

policy will be updated. Keep the most recent copy.

Equipment purchase records

If you buy a clothes dryer, a vacuum, a garage door opener or some other appliance or equipment, keep the receipt as long as you own that item. These receipts will come in handy if something breaks, doesn't work, or is stolen. If repair work is needed, it may be covered under warranty.

The receipt should show the following:

- Salesperson's name and address
- Serial number or other information to identify the item
- How much you paid
- Date of purchase

Most equipment comes with a warranty and a use and care manual. Keep these documents as well, to maintain the item and in case you have a problem. While product warranties are often limited to one year, keep receipts and use and care manuals as long as you keep the equipment. Keep receipts for repairs and repair warranties as well.

Receipts for work done on the house

If you have your home reroofed or your furnace repaired, keep the receipt and any warranty materials the contractor gives you. The receipt should show the following:

- Contractor's name and address
- Description of the work done
- How much you paid
- Date you paid the bill

These receipts can be useful to:

- Ensure a problem with the work gets corrected.
- Document improvements for tax purposes.*
- Justify increases in the asking price when you sell the property.
- Answer questions from potential buyers.

Keep receipts for work done as long as you own the house, or until the work is redone.

* **Note:** Not all work you do on your house qualifies as an improvement for tax purposes. To be counted as an improvement, the work you do must add to the market value of the property. Painting and other maintenance and repairs generally are not counted as improvements. But keep the receipts, and figure out what you can use for tax purposes later.

Developing a filing system

Some people just throw into a box or drawer all the papers they want to keep. This can create some problems:

- Papers may be lost.
- Papers may be wrinkled or damaged.
- It's hard to find the paper you want when you need it.

If you don't have a file cabinet or a file drawer in a desk, consider buying sturdy file boxes with dividers. Keep a separate file box for mortgage and other documents related directly to the purchase of your home. You might use the following file headings:

- Appliance manuals
- Home improvements
- Home insurance
- Mortgage
- Property taxes

Adapted with permission from:

Homeowner Filing System by Linda Redmann (Clemson, SC: Clemson University Cooperative Extension Service).

Prepared by John Merrill, extension housing specialist, UW-Madison.

R-02



Quick reference list

Emergency contacts

Post these numbers by each phone for easy access in case of an emergency. If you have school age children, teach them how to make emergency calls, and give a copy of this to a trusted neighbor who is usually home. You may also wish to add parent's work number(s).

Emergency telephone numbers 911 or

Ambulance service/rescue _____

Fire department _____

Poison Control Center _____

Police department _____

Non-emergency telephone numbers

Electric company _____

Furnace service _____

Name _____

Gas company _____

Plumber _____

Water and sewer department _____

Block club/neighborhood organization _____

Snow removal service _____

Homeowner's insurance agent

Name _____

Policy number _____

Renewal date _____

Housing inspector

Name _____

Date of inspection _____

Home builder — New home

Name _____

Address _____

Mortgage lender

Name _____

Address _____

Property tax office

Name _____

Address _____

UW-Extension county office

Name _____

Address _____

Waste disposal

Name _____

Others: _____

Name _____

Address _____

Phone _____

Name _____

Address _____

Phone _____

Name _____

Address _____

Phone _____

Name _____

Address _____

Phone _____

Name _____

Address _____

Phone _____

Name _____

Address _____

Phone _____

Name _____

Address _____

Phone _____

Name _____

Address _____

Phone _____

You may want to add:

School _____

School bus service _____

Doctor _____

Parent's work _____

Home Wise

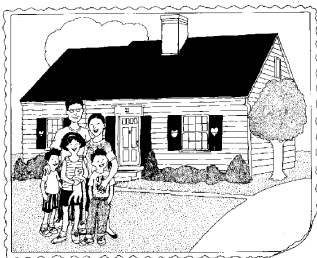

Homeowner resources

County UW-Extension Office

(listed under county government in your phone book)

Your county UW-Extension office has more publications for homeowners, and offers educational programs on specific topics covered in this manual. For example, many counties offer Money 2000 and Beyond programs to help you plan your spending, reduce your debt and increase your savings. Easy-to-read nutrition and financial management publications (some in Spanish) are prepared for Wisconsin Nutrition Education Programs. Ask your county UW-Extension family living agent for more information.

Publications are available from your county UW-Extension office or the address on the back page.

Consumer Credit (series, also in Spanish, Crédito al Consumidor):

- **Shopping for Consumer Credit (NCR606-1)**
How much extra does it cost to buy on credit? Before you borrow money or sign a credit card contract, look for the best deal. Know what to look for when you shop for credit. Includes worksheets.
- **When There's an Error on Your Credit Card Bill (NCR606-2)**
Learn how to protect yourself from these billing errors: wrong description, amount or date; charges you did not make or by a person not authorized to use your account; failures to credit your account or deliver a billing statement to your current address; or accounting mistakes such as finance charges.

- **Your Credit Report (NCR606-3)**
Want to buy a house or car? Learn how to get copies of your credit record, what the items listed mean, and how to correct errors **before** you apply for a loan. Turned down for credit? Knowing your rights can save you money.

Credit Card Smarts (NCR 613)

This packet is an excellent companion to use with the Consumer Credit series above. Credit Card Smarts fact sheets:

- Build a New Credit Record
- Check Your Credit Report
- Choose the Best Credit Card
- Choose the Best Credit Card Interest Rate
- Control Your Holiday Credit Card Debt
- Decide How Many Credit Cards You Need
- Decide How Much Credit is Too Much
- Get Rid of Credit Card Debt
- Protect Your Credit Information
- Fair Credit Reporting Act Update

Cost of Raising Children (NCR440)

How much of a family's yearly income is spent on children? With accurate spending records, families can plan for future costs, prepare for emergencies, determine support needs on divorce, and purchase enough life insurance to support children if a parent dies.

Family Keys: Self-Care Resources for Children and Their Families (NCR597)

Your children may be on the verge of being able to take care of themselves. But first, they need to learn how to react in an emergency, what rules to follow, and what to do if they become bored or lonely. These skills and more are covered in 13 lesson sheets, with use tips.

HomeWorks News (B3731)

This newsletter series is created to help you through your first year as a homeowner. Each quarterly issue includes a seasonal home care checklist of indoor and outdoor tasks, backed by articles with maintenance tips and financial management information for coming months.

Investing for Your Future: A Cooperative Extension System Basic Investing Home Study Course (B71FYF)

This home study course can give you the basic tools you need to keep contributing to retirement plans and other savings goals. Good companion to *Investment Basics B3683*.

Investment Basics (B3683)

Overwhelmed by financial information you see in newspapers or magazines, on the Internet or TV? Introduces common savings and investment options to help the beginning Wisconsin investor start an investment plan. The more you know, the better you can sort through all this material and make your own investment decisions. Follow the basics with the home study course above.

Maintaining Your Home: Lead-Based Paint Hazards (B3628)

If there are young children in your household, here's more on how to find and fix lead paint hazards to prevent lead poisoning. Lead poisoning can only be prevented — not cured. When you buy or rent, housing owners must now disclose any lead paint hazards.

Money 2000 and Beyond (series):

- **Organizing Your Financial Records (B3709-1)**
At tax time, are you hunting through piles of papers for receipts and medical expenses? Here are tips on filing and where to keep important papers, guidelines and a worksheet for figuring your net worth.
- **Taking Control of Your Spending (B3709-2)**
How do you spend your money? How do you **want** to spend it? Clarify your financial goals and develop a spending plan that will get you where you want to go, using guidelines and worksheets. Use with the video "Take Control of Your Spending," available through your county UW-Extension office.
- **Tracking Your Spending (B3709-3)**
How can you track your spending to stay within your spending plan? Keeping a record of expenditures is an important part of planning and controlling your spending. These tracking methods will help guide you in achieving a more secure financial future. Choose the one that works best for you.

- **Using Power Payments to Pay Off Debt (B3709-4)**
Want to get out of debt faster and save money in the process? As soon as you pay off one debt, roll that monthly amount — the power payment — over to another debt until you repay all creditors. The total amount you pay stays the same.
- **Using a Check Register to Track Your Expenses (B3709-5)**
- **Use with: Check Register Tracking System (B3709-6)**
Can you afford further expenditures based on your spending plan? Describes a management technique that shows exactly how much you have spent and have left to spend for each expense category. Use the system to track all your expenses — whether by cash, check, credit or debit card — without spending a lot of time. Use with Check Register Tracking System B3709-6 and other publications in this series to track and spend your money wisely.

Our Family Records (B2369)

Need your work history for an interview? Immunization records so your child can start school? Keep tabs on important personal and financial records — for yourself, and for others who may have to handle your affairs if you can't. Quick references in case of emergency, and record keeping guidelines for financial planning, including marital property in Wisconsin.

Planning to Stay Ahead: Dollars and Cents (B3478)

Easy-to-read guidelines and worksheets for helping families make good financial decisions. Earned Income Credit (EIC) amounts for the current tax year are updated on the Web at:
www.uwex.edu/ces/eic

Web sites

If you do not have a computer, try your local library. Most libraries have a computer connected with the Internet.

About the House: Solutions for Home Care Problems

www.uwex.edu/ces/flp/house

Environmental Resources Center

www.uwex.edu/erc

*Farm*A*Syst Program*

www.uwex.edu/farmasyst

*Home*A*Syst Program*

www.uwex.edu/homeasyst

Money 2000 & Beyond

www.uwex.edu/ces/money2000

Parenting (English and Spanish)

www.uwex.edu/ces/flp/parenting

Property taxes — You can find information and a property tax bill explained in the on-line publication Guide for Property Owners. Click on “Local government publications” at the Wisconsin Department of Revenue Web site

www.dor.state.wi.us

Publications

www1.uwex.edu/ces/pubs

Small Scale Waste Management Project,

UW-Madison (608-265-6595)

www.wisc.edu/sswmp

Training for home ownership counseling is available from UW-Extension. Contact Kim Terry at Milwaukee County Extension office.

e-mail: kim.terry@ces.uwex.edu

This publication contains copyright protected material. Permission is required from each copyright owner before reproducing or reprinting.

© **2002** by the Board of Regents of the University of Wisconsin System doing business as the division of Cooperative Extension of the University of Wisconsin-Extension. Send inquiries about copyright permission to: Director, Cooperative Extension Publications, 103 Extension Bldg., 432 N. Lake St., Madison, WI 53706.

Authors: John Merrill, professor, Department of Environment, Textiles and Design, University of Wisconsin-Madison, and housing specialist, UW-Extension; Atiya Mahmood, former housing state specialist, University of Missouri-Extension; Phillip Pellitteri, distinguished outreach specialist in entomology, UW-Extension, and Insect Diagnostic Lab, UW-Madison; and Kim Terry, housing and financial management educator, UW-Extension. Rosalie Powell was a professor and family resource management agent for Milwaukee County UW-Extension (1995). The authors thank staff of the Wisconsin Department of Health and Family Services Division of Public Health, and Department of Revenue.

Produced by Cooperative Extension Publications, UW-Extension; Rhonda Lee, editor. Illustrations by Hawley Wright and John Merrill.

Reviewers: Linda Boelter, family financial management specialist, University of Wisconsin-Extension; Don Cohen, community lending manager, Milwaukee; Dawn Davis, loan officer, M&I Marshall and Ilsley; Richard Gotz, home inspector, East Troy; Michael Hallenbeck, employee assistance consultant, UW-Extension; Anne Landre, director, Community Insurance Information Center, Milwaukee; Mary Fran Lepeska, associate professor and family living educator, Ozaukee County UW-Extension; Jacobo Lovo, post purchase homeownership counselor, Housing Resources, Milwaukee; Atiya Mahmood, former housing state specialist, University of Missouri-Extension; Jim Morovic, safety education officer, Madison Police Department; Phillip Pellitteri, distinguished outreach specialist in entomology, UW-Extension, and Insect Diagnostic Lab, UW-Madison; Roger Williams, professor and chairperson, Professional Development and Applied Studies, UW-Madison; and Doug Woodard, associate program leader, Affordable Housing, Michigan State University Extension.

University of Wisconsin-Extension, Cooperative Extension, in cooperation with the U.S. Department of Agriculture and Wisconsin counties, publishes this information to further the purpose of the May 8 and June 30, 1914, Acts of Congress. UW-Extension provides equal opportunities and affirmative action in employment and programming, including Title IX and ADA requirements. If you need this material in an alternative format, contact Cooperative Extension Publications at (608) 262-2655 (Voice & TDD), or the UW-Extension Office of Equal Opportunity and Diversity Programs. Before publicizing, please check this publication's availability.

This publication is available from your Wisconsin county UW-Extension office or:

Cooperative Extension Publications
45 N. Charter St., Madison, WI 53715
Toll-free: (877) 947-7827 (877-WIS-PUBS)
Madison: 262-3346; Fax: (608) 265-8052
Internet: www1.uwex.edu/ces/pubs

